

Axles and Components

MERITOR AXLES	1-1
DANA SPICER AXLES	1-1
AXLE ASSEMBLIES	1-2
BRAKE SHOES	1-3
BRAKE SHOE REPAIR KITS	1-4 TO 1-6
BRAKE SPIDER	1-6
BRAKE SHOE HARDWARE	1-7
BRAKE CAM SHAFTS	1-8 TO 1-10
CAM SHAFT REPAIR KITS	1-11 TO 1-12
CAM SHAFT BUSHINGS & SUPPORT BRACKETS	1-13
CAM SHAFT WASHERS, LOCK RINGS, & SEALS	1-14
MANUAL SLACK ADJUSTERS	1-15
AUTOMATIC SLACK ADJUSTERS	1-15 TO 1-17
DUST SHIELDS	1-17
AXLE NUTS & WASHERS	1-18
BEARINGS & RACES	1-19
OIL SEAL INTERCHANGE	1-20
OIL SEALS	1-21
STEMCO HUB CAPS, GASKETS, WINDOW KITS, & VENT PLUGS	1-21
MISC. HUB CAPS, GASKETS, & VENT PLUGS	1-22
HUBODOMETER MOUNTING BRACKETS	1-23
HUBODOMETERS	1-24

5-inch Round Axles



Meritor

Part Number	Track	Bearing Combination		Wall Thickness	Brake Size	Capacity	Cam Length	Cam Shaft 28 Tooth	Cam Bushing Kit
		Inner	Outer						
RW-TN4671QR1150	71-1/2"	HM218248	HM212049	1/2"	16-1/2" X 7"	22,500#	17-5/16"	700-7-272 (R.H.) 700-7-273 (L.H.)	700-7-286
RW-TQ4671QR1350	71-1/2"	HM218248	HM212049	5/8"	16-1/2" X 7"	25,000#	24-1/16"	700-7-274 (R.H.) 700-7-275 (L.H.)	700-7-286
RW-TP4671QR1250	71-1/2"	HM518445	HM518445	1/2"	16-1/2" X 7"	22,500#	17-5/16"	700-7-272 (R.H.) 700-7-273 (L.H.)	700-7-286
RW-TN4671QR7150	77-1/2"	HM218248	HM212049	1/2"	16-1/2" X 7"	22,500#	17-5/16"	700-7-272 (R.H.) 700-7-273 (L.H.)	700-7-286
RW-TN4671LR7250	77-1/2"	HM218248	HM212049	1/2"	16-1/2" X 7" Q Plus	22,500#	17-5/16"	700-7-272 (R.H.) 700-7-273 (L.H.)	700-7-286
RW-TQ4671QR7350	77-1/2"	HM218248	HM212049	5/8"	16-1/2" X 7"	25,000#	24-1/16"	700-7-274 (R.H.) 700-7-275 (L.H.)	700-7-286
RW-TQ4671LR7350	77-1/2"	HM218248	HM212049	5/8"	16-1/2" X 7" Q Plus	25,000#	24-1/16"	700-7-274 (R.H.) 700-7-275 (L.H.)	700-7-286
RW-TP4671QR7150	77-1/2"	HM518445	HM518445	1/2"	16-1/2" X 7"	22,500#	17-5/16"	700-7-272 (R.H.) 700-7-273 (L.H.)	700-7-286
RW-TP8671QR7350	77-1/2"	HM518445	HM518445	5/8"	16-1/2" X 7"	25,000#	24-1/16"	700-7-274 (R.H.) 700-7-275 (L.H.)	700-7-286

Dana Spicer

Part Number	Track	Bearing Combination		Wall Thickness	Brake Size	Capacity	Cam Length	Cam Shaft 28 Tooth	Cam Bushing Kit
		Inner	Outer						
DA-D22AX503A624	71-1/2"	HM218248	HM212049	1/2"	16-1/2" X 7"	22,500#	17-3/8"	M16WKR25-175 (R.H.) M16WKL25-175 (L.H.)	DA-M10KY105
DA-D22AX603A1275	71-1/2"	HM218248	HM212049	5/8"	16-1/2" X 7"	25,000#	23-3/4"	700-7-298 (R.H.) 700-7-297 (L.H.)	DA-M10KY105
DA-D22AX6031500	71-1/2"	HM218248	HM212049	5/8"	12-1/4" X 7-1/2"	25,000#	23-1/8"	M12WKR25-233 (R.H.) M12WKL25-233 (L.H.)	DA-M10KY105
DA-D21AX50354	71-1/2"	663	HM212049	7/16"	16-1/2" X 7"	22,500#	20-7/16"	700-7-296 (R.H.) 700-7-295 (L.H.)	DA-M10KY105
DA-D22AX503A1279	77-1/2"	HM218248	HM212049	1/2"	16-1/2" X 7"	22,500#	17-3/8"	M16WKR25-175 (R.H.) M16WKL25-175 (L.H.)	DA-M10KY105
DA-D22AX603A1276	77-1/2"	HM218248	HM212049	5/8"	16-1/2" X 7"	25,000#	23-3/4"	700-7-298 (R.H.) 700-7-297 (L.H.)	DA-M10KY105

5-inch Round Axle Assemblies



Hub Piloted

Part Number	Track	Axle	Hub	Drum	ABS Ready
700-60-29	71-1/2"	RW-TN4671QR1150	DW-04-15571-001	DW-03-123207	Yes
700-60-29-1	77-1/2"	RW-TN4671QR7150	DW-04-15571-001	DW-03-123207	Yes
700-60-30	71-1/2"	RW-TQ4671QR1350	DW-04-15571-001	DW-03-123207	Yes
700-60-30-1	77-1/2"	RW-TQ4671QR7350	DW-04-15571-001	DW-03-123207	Yes
Above axle assemblies include: Hub Pilot Hub and Drum Assemblies					
6-Hole Hub Caps and Bolts					
Inner and Outer Bearing Cones					
Oil Seals					

Stud Piloted

Part Number	Track	Axle	Hub	Drum	ABS Ready
700-60-12	71-1/2"	RW-TN4671QR1150	DW-04-15501-001	DW-03-123207	No
700-60-12-1	77-1/2"	RW-TN4671QR7150	DW-04-15501-001	DW-03-123207	No
700-60-28	71-1/2"	RW-TQ4671QR1350	DW-04-15501-001	DW-03-123207	No
700-60-28-1	77-1/2"	RW-TQ4671QR7350	DW-04-15501-001	DW-03-123207	No
Above axle assemblies include: Stud Pilot Outboard Hub and Drum Assemblies					
6-Hole Hub Caps and Bolts					
Inner and Outer Bearing Cones					
Oil Seals					

Pressed Steel Brake Shoes

Eaton-type Unlined Shoe



Part No.	Brake Size	Block No.	Type Shoe
7-A3-128	16-1/2" X 7"	4311G 1/4" Dia. Holes	Quick Change

Fruehauf-type Unlined Shoe



Part No.	Brake Size	Block No.	Type Shoe
7-A3-132	16-1/2" X 7"	4515 1/4" Dia. Holes	3rd Design

Meritor-type Unlined Shoe

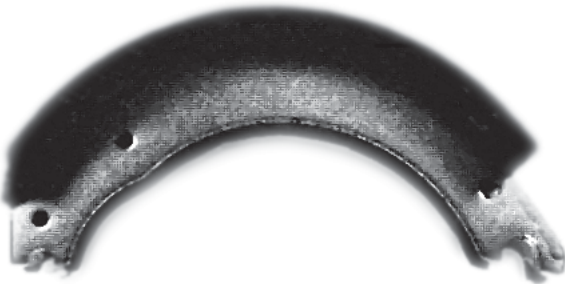

Part No.	Brake Size	Block No.	Type Shoe
7-A3-127	16-1/2" X 7"	4515 1/4" Dia. Holes	Quick Change

Meritor-type Lined Shoe

Part No.	Brake Size	Type Lining	Type Shoe
CA-TM4515QSP	16-1/2" X 7"	Carlisle MB 21	Quick Change
Edge code on brake lining is Trailmobile private label			



Brake Shoe Repair Kits

16-1/2" Q SERIES BRAKES

Standard

700-7-235
with knurled rollers

RW-KIT8000

These kits can replace
Euclid E-2769S

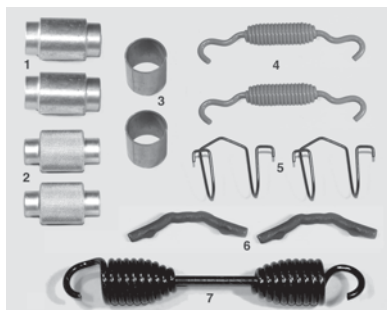

Item	Qty	Part No.	Description
1	2	KC1022	Anchor Pin
2	2	KC1012K	Knurled Roller
3	2	KC1062	Stainless Steel Bushing
4	2	KC1032	Retainer Spring
5	2	KC1052Q	Roller Retainer
6	2	KC1072	Spring Pin
7	1	KC1041	Standard Return Spring

Heavy Duty

700-7-239
with knurled rollers

This kit can replace
Euclid E-2769SHD

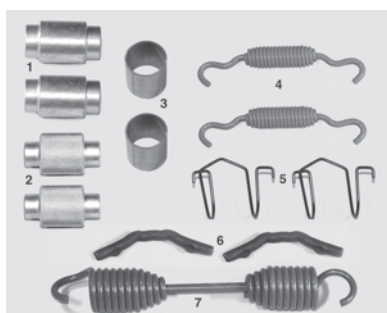

Item	Qty	Part No.	Description
1	2	KC1022	Anchor Pin
2	2	KC1012K	Knurled Roller
3	2	KC1062	Stainless Steel Bushing
4	2	KC1032	Retainer Spring
5	2	KC1052Q	Roller Retainer
6	2	KC1072	Spring Pin
7	1	KC1241-375	Heavy Duty Return Spring

700-7-257
with knurled rollers
(Also as 700-7-257-BAG)

This kit can replace
Euclid E-6999SHD

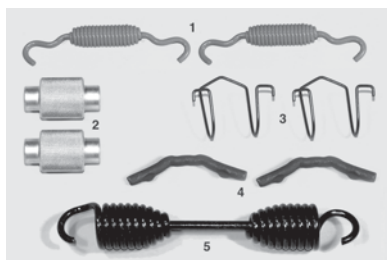

Item	Qty	Part No.	Description
1	2	KC1032	Retainer Spring
2	2	KC1012K	Knurled Roller
3	2	KC1052Q	Roller Retainer
4	2	KC1072	Spring Pin
5	1	KC1241	Heavy Duty Return Spring

700-7-262
with knurled rollers

This kit can replace
Euclid E-6999SHD

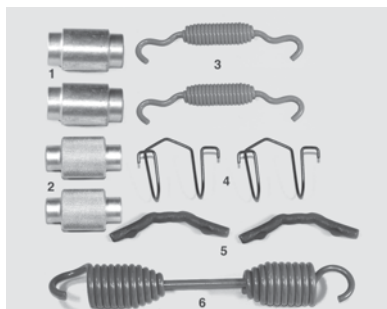

Item	Qty	Part No.	Description
1	2	KC1022	Anchor Pin
2	2	KC1012K	Knurled Roller
3	2	KC1032	Retainer Spring
4	2	KC1052Q	Roller Retainer
5	2	KC1072	Spring Pin
6	1	KC1241-375	Heavy Duty Return Spring

700-7-263
with knurled rollers

This kit can replace
Euclid E-3895SHD

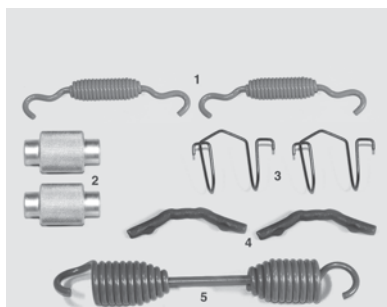

Item	Qty	Part No.	Description
1	2	KC1032	Retainer Spring
2	2	KC1012K	Knurled Roller
3	2	KC1052Q	Roller Retainer
4	2	KC1072	Spring Pin
5	1	KC1241-375	Heavy Duty Return Spring 8-3/8" Length

Brake Shoe Repair Kits

16-1/2" P SERIES BRAKES

Heavy Duty
700-7-258
with knurled rollers

This kit can replace
Euclid E-1816SHD

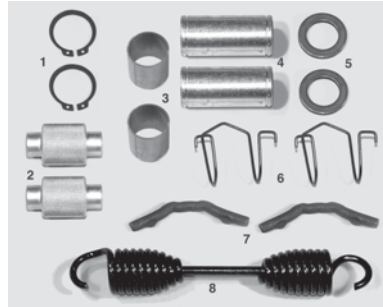

Item	Qty	Part No.	Description
1	4	KC15E4	Lock Ring
2	2	KC1012K	Knurled Roller
3	2	KC1062	Stainless Steel Bushing
4	2	KC1522	Anchor Pin
5	4	KC1584	Washer
6	2	KC1052Q	Roller Retainer
7	2	KC1072	Spring Pin
8	1	KC1541	HD Return Spring 8" Length

16-1/2" FRUEHAUF XEM LATE MODEL SERIES

Standard
700-7-259
with knurled rollers
(Also as 700-7-259-BAG)

This kit can replace
Euclid E-3710S

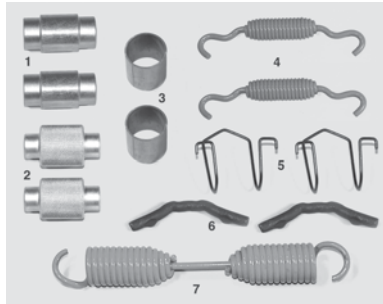

Item	Qty	Part No.	Description
1	2	KC2022	Anchor Pin
2	2	KC1012K	Knurled Roller
3	2	KC1062	Stainless Steel Bushing
4	2	KC1032	Retainer Spring
5	2	KC1052Q	Roller Retainer
6	2	KC1072	Spring Pin
7	1	KC1041	STD Return Spring 8-3/8" Length

Heavy Duty
700-7-238
with knurled rollers

This kit can replace
Euclid E-3710SHD

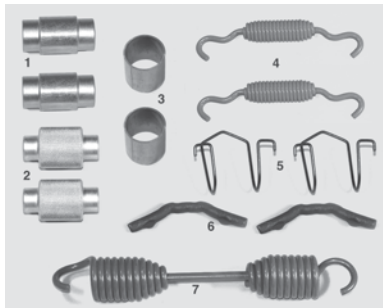

Item	Qty	Part No.	Description
1	2	KC2022	Anchor Pin
2	2	KC1012K	Knurled Roller
3	2	KC1062	Stainless Steel Bushing
4	2	KC1032	Retainer Spring
5	2	KC1052Q	Roller Retainer
6	2	KC1072	Spring Pin
7	1	KC1241-375	HD Return Spring 8-3/8" Length

15" FRONT BRAKES

Q
Standard
700-7-305

This kit can replace
Euclid E-7899

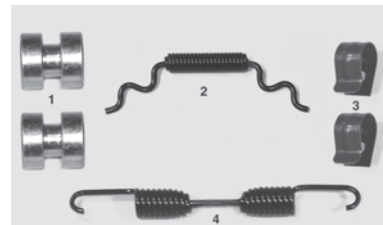

Item	Qty	Part No.	Description
1	2	KC1112	Roller
2	1	KC1131	Retainer Spring
3	2	KC11A2	Shoe Clip
4	1	KC1341	Return Spring 7-11/16" Length

EATON
Standard
700-7-304

This kit can replace
Euclid E-5139

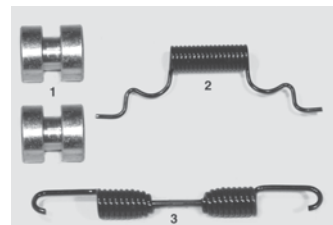

Item	Qty	Part No.	Description
1	2	KC1112	Roller
2	2	KC3131	Retainer Spring
3	1	KC3141	Return Spring 7-1/8" Length

Brake Shoe Repair Kits

16-1/2" EATON

Heavy Duty

700-7-237

with knurled rollers
(Also as 700-7-237-BAG)

This kit can replace
Euclid E-1887ASHD

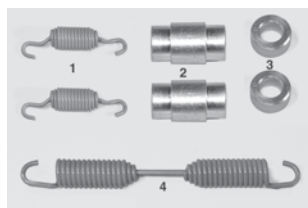

Item	Qty	Part No.	Description
1	2	KC3032	Retainer Spring
2	2	KC3022	Roller Pin
3	2	KC3012K	Knurled Roller
4	1	KC3241	HD Return Spring 10-13/16" Length

16-1/2" EATON ES

Heavy Duty

700-7-306

with knurled rollers

This kit can replace
Euclid E-5481A

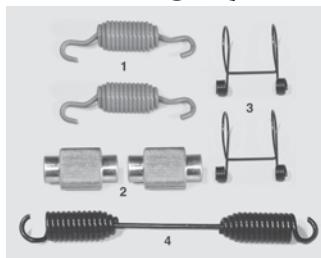

Item	Qty	Part No.	Description
1	2	KC3032	Retainer Spring
2	2	KC3212K	Knurled Roller
3	2	KC3452	Roller Retainer
4	1	KC3441	HD Return Spring 10-3/4" Length

16-1/2" EATON ES II

Heavy Duty

700-7-307

with knurled rollers

This kit can replace
Euclid E-10244

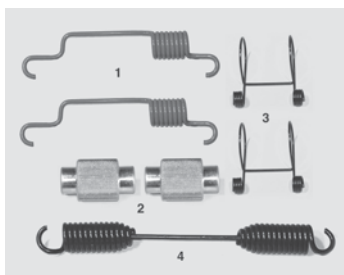

Item	Qty	Part No.	Description
1	2	KC3432	Retainer Spring
2	2	KC3212K	Knurled Roller
3	2	KC3452	Roller Retainer
4	1	KC3441	HD Return Spring 10-3/4" Length

Brake Spider

Adjustable Brake Spider

700-7-23

5-3/8" Dia. Pilot Hole

6-5/8" Hole Centers

For 1-2" Studs



Adjustable Anchor Pin Housing.
Nylon Bushing Installed.







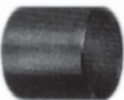

This adjustable brake spider can replace
Euclid E-957

Meritor A-3211-A-833

Standard Forge 200999-010

Brake Shoe Hardware

1

	Part No.	O.D.	Length	Replaces	Note
	700-7-206	1-1/4"	2-7/32"	Euclid E-2177	Knurled roller for 16-1/2" brakes with fabricated brake shoes
	700-7-33	1-3/8"	1-29/64"	Euclid E-1893 Meritor 1225-B-496	For use with no-slot anchor pin
	700-7-21	1-1/8"	8"	Euclid E-545A Meritor 2258-P-354	For standard 'P' style brakes
	700-7-142	1-1/8"	8-3/8"	Euclid E-2768 Meritor 2258-U-619	For Spicer 'Fast Change' and Meritor 'Q' brakes
	700-7-141	3/4"	5-1/2"	Euclid E-2767 Meritor 2258-Q-615	For Fruehauf 'XEM' brakes and Meritor 'Q' brakes
	700-7-22			Euclid E-747 Meritor 1218G-85	Used on Meritor, Fruehauf, and Spicer with fabricated brake shoes
	700-7-28			Euclid E-801 Meritor 1229-X-1116	Used on 1-1/4" anchor pins with grooves
	700-7-29			Euclid E-1113 Meritor 1229-B-1848	1-7/8" O.D. ; 1-17/64" I.D.
	700-7-19			Euclid E-539 Meritor 1718-Y-103	Used with new style brake shoe rollers
	700-7-147			Euclid E-3007A Meritor 3105-B-210	Used on Meritor 'Q' brakes

Brake Cam Shafts

Cams — S-Head Identification

View from
Head End

L.H. — Cams



R.H. — Cams

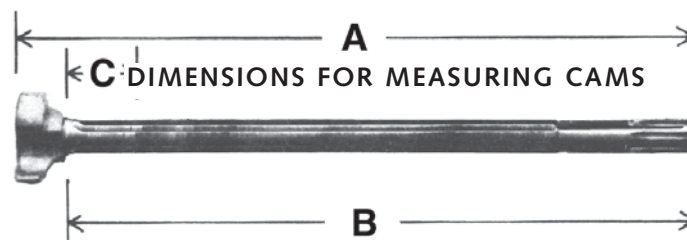

MULTIPLE USE 1-1/2" 10-SPLINE

Part No.	Overall Length A	Under Head B	To Groove C	Pos.	Replaces	Note
700-7-30	25-15/16"	24"	2-7/32"	R.H.	Meritor 2210-C-6399S Euclid E-4716	
700-7-31	25-15/16"	24"	2-7/32"	L.H.	Meritor 2210-C-6400S Euclid E-4717	
700-7-176	26"	23-3/4"	2-7/32"	R.H.	Eaton 125031 Euclid E-4720	1-1/2" Dia. Spline 1-5/8" Dia. Under Head
700-7-175	26"	23-3/4"	2-7/32"	L.H.	Eaton 125030 Euclid E-4721	
700-7-188	22"	19-1/2"	2-7/32"	R.H.	Eaton 125035 Euclid E-2694	1-1/2" Dia. Spline 1-5/8" Dia. Under Head
700-7-187	22"	19-1/2"	2-7/32"	L.H.	Eaton 125034 Euclid E-2693	
700-17-236	22-7/16	20-3/8"	1-5/8" & 2-7/32"	R.H.	Meritor 2210-E-5413 Euclid E-1424	For Paymaster RL & RN Axles
700-17-237	22-7/16	20-3/8"	1-5/8" & 2-7/32"	L.H.	Meritor 2210-E-5414 Euclid E-1425	
700-17-238	23-1/8"	21-3/32"	2-7/32"	R.H.	Meritor 2210-Z-6318 Euclid E-684	
700-17-239	23-1/8"	21-3/32"	2-7/32"	L.H.	Meritor 2210-A-6319 Euclid E-685	
700-17-243	25-1/8"	23-7/16"	2-5/16"	R.H.	Meritor R607001 Euclid E-1094	Used on Axles with Air Ride Suspensions
700-17-242	25-1/8"	23-7/16"	2-5/16"	L.H.	Meritor R607002 Euclid E-1095	
700-17-244	13-3/4"	11-1/2"	1-3/4"	R.H.	Meritor 2210-C-5359 Euclid E-1147B	Used on Meritor STD TU-267 & 287 Axles
700-17-245	13-3/4"	11-1/2"	1-3/4"	L.H.	Meritor 2210-D-5360 Euclid E-1148B	

28-SPLINE 1-1/2" Dia. Spline 1-5/8" Dia. Under Head

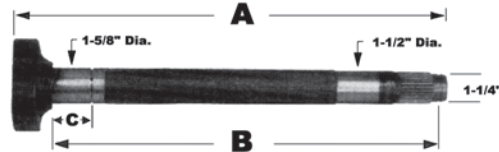

Note: Dimension shown is from shoulder of camhead to far edge of lock ring groove.

Part No.	Overall Length A	Under Head B	To Groove C	Pos.	Replaces	Note
7-5-107 See Note Below	19-1/8"	17-5/16"	1-25/32"	R.H.	Meritor 2210-L-4328 Euclid E-2442A	Used on Meritor TN Axles with Spring Suspension
7-5-108 See Note Below	19-1/8"	17-5/16"	1-25/32"	L.H.	Meritor 2210-M-4329 Euclid E-2441A	
7-5-111 See Note Below	22-1/4"	20-13/32"	1-25/32"	R.H.	Meritor 2210-Q-4333 Euclid E-2444A	
7-5-112 See Note Below	22-1/4"	20-13/32"	1-25/32"	L.H.	Meritor 2210-R-4334 Euclid E-2443A	
7-5-113 See Note Below	25-7/8"	24-1/16"	1-25/32"	R.H.	Meritor 2210-N-4330 Euclid E-2446A	Used on Meritor TQ Axles with Air Ride Suspension
7-5-114 See Note Below	25-7/8"	24-1/16"	1-25/32"	L.H.	Meritor 2210-P-4332 Euclid E-2445A	
700-7-272	19-1/8"	17-5/16"	1-25/32" & 2-5/64"	R.H.	Meritor 2210-B-6866 Euclid E-5507	Q Plus Style
700-7-273	19-1/8"	17-5/16"	1-25/32" & 2-5/64"	L.H.	Meritor 2210-C-6867 Euclid E-5506	
700-7-274	25-7/8"	24-1/16"	1-25/32" & 2-5/64"	R.H.	Meritor 2210-D-6868 Euclid E-5511	
700-7-275	25-7/8"	24-1/16"	1-25/32" & 2-5/64"	L.H.	Meritor 2210-E-6869 Euclid E-5510	
700-7-295	22-1/2"	20-7/16"	1-5/8" & 2-7/32"	L.H.	Spicer M16WKL25-205 Euclid E-9733	Used on Axles Serial Number 95J172527 to Current
700-7-296	22-1/2"	20-7/16"	1-5/8" & 2-7/32"	R.H.	Spicer M16WKR25-205 Euclid E-9734	
700-7-297	25-9/16"	23-1/2"	2-7/32"	L.H.	Spicer M16WKL25-236 Euclid E-9735	
700-7-298	25-9/16"	23-1/2"	2-7/32"	R.H.	Spicer M16WKR25-236 Euclid E-9736	
700-7-299	26"	24"	2-7/32"	L.H.	Spicer M16WKL25-242 Euclid E-10909	
700-7-300	26"	24"	2-7/32"	R.H.	Spicer M16WKR25-242 Euclid E-10910	

Note: Cam Shaft part numbers 7-5-107 through 7-5-114 have Q+ style heads. For maximum brake life and performance, these cam shafts should be replaced in pairs.

Brake Cam Shafts

28-SPLINE 1-1/2" Dia. Spline 1-1/2" Dia. Under Head

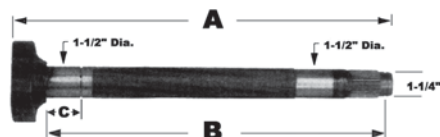

Note: Dimension shown is from shoulder of camhead to far edge of lock ring groove.

Part No.	Overall Length A	Under Head B	To Groove C	Pos.	Replaces	Note
700-7-282	25-3/8"	23-9/16"	1-5/8" & 2-7/32"	L.H.	Spicer M16WKL20-236 Euclid E-5526	
700-7-283	25-3/8"	23-9/16"	1-5/8" & 2-7/32"	R.H.	Spicer M16WKR20-236 Euclid E-5527	
700-7-289	26-1/8"	24-1/16"	1-5/8" & 2-7/32"	L.H.	Spicer M16WKL20-242 Euclid E-9100	
700-7-290	26-1/8"	24-1/16"	1-5/8" & 2-7/32"	R.H.	Spicer M16WKR20-242 Euclid E-9101	
700-7-293	22-1/2"	20-7/16"	1-5/8" & 2-7/32"	L.H.	Spicer M16WKL20-205 Euclid E-5524	
700-7-294	22-1/2"	20-7/16"	1-5/8" & 2-7/32"	R.H.	Spicer M16WKR20-205 Euclid E-5525	

28-SPLINE 1-19/32" Dia. Spline 1-5/8" Dia. Under Head

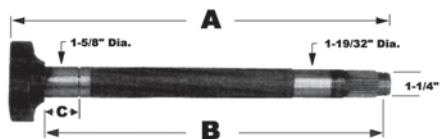

Note: Dimension shown is from shoulder of camhead to far edge of lock ring groove.

Part No.	Overall Length A	Under Head B	To Groove C	Pos.	Replaces	Note
700-7-291	18-1/8"	16-1/8"	2-5/32"	L.H.	Fruehauf APA-0998-1 Euclid E-9761	Used on Pro-Par Axles
700-7-292	18-1/8"	16-1/8"	2-5/32"	R.H.	Fruehauf APA-0998-2 Euclid E-9762	

37-SPLINE 1-19/32" Dia. Spline 1-5/8" Dia. Under Head

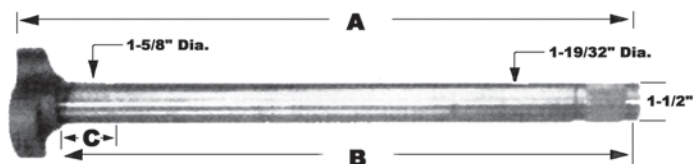

Part No.	Overall Length A	Under Head B	To Groove C	Pos.	Replaces	Note
700-17-247	18-1/8"	16-1/8"	2-5/32"	R.H.	Fruehauf AXA-0420-2 Euclid E-1564	Used on Pro-Par Axles
700-17-246	18-1/8"	16-1/8"	2-5/32"	L.H.	Fruehauf AXA-0420-1 Euclid E-1563	
700-17-332	22-7/8"	21-1/8"	2-5/32"	R.H.	Fruehauf AXA-0420-4 Euclid E-2100	
700-17-333	22-7/8"	21-1/8"	2-5/32"	L.H.	Fruehauf AXA-0420-3 Euclid E-2099	

Cam Shaft Repair Kits

Meritor 1-5/8" Dia. Cam Shafts

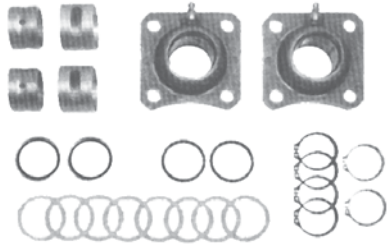

700-7-248

This kit can replace:
Euclid E-3520A
Sirco B8683

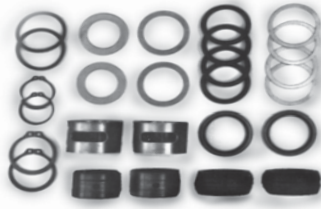

700-7-249

This kit can replace:
Sirco B8645



700-7-9

This kit can replace:
Sirco B8645A



Meritor 1-1/2" Dia. Cam Shafts

700-7-7

This kit can replace:
Euclid E-2088AHD

Meritor Axles with Fabricated Spiders



RW-KIT8289

This kit can replace:
Euclid E-6078



700-7-286

This kit can replace:
Euclid E-9079HD

Fruehauf Pro-Par

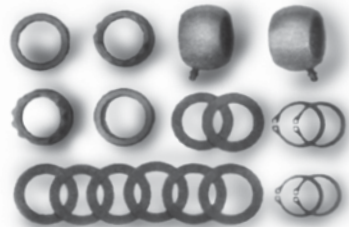

700-7-245

This kit can replace:
Euclid E-2090
Sirco B8649



700-7-169

This kit can replace:
Sirco B8649A

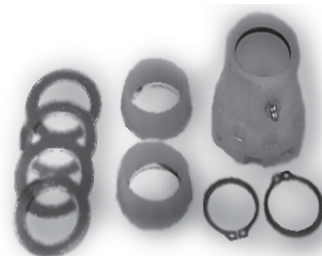

700-7-8

Early Model

Cam Shaft Repair Kits

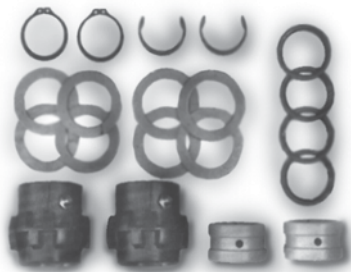

**Eaton 501 Series
Brakes**

700-7-303

This kit can replace:
Euclid E-2696A

Dana Spicer 1-1/2" Dia. Cam Shafts



DA-M16KY202

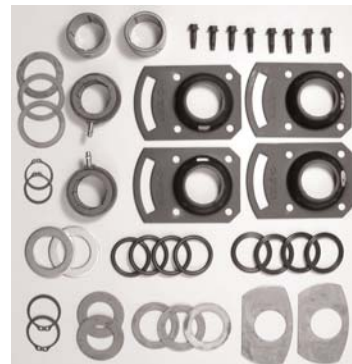



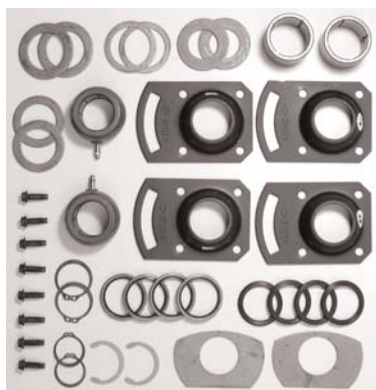





DA-M10KY106





**Dana Spicer
1-5/8" Dia. Cam Shafts**

DA-M10KY105

Cam Shaft Bushings & Brackets

Bushing	Part No.	O.D.	I.D.	Length	Note
	700-7-32	1-7/8"	1-1/2"	1-1/4"	Euclid E-536 Used in Kit 700-7-6
	700-7-33	1-7/8"	1-1/2"	1-1/2"	Euclid E-2291 Used in Kit 700-7-7
	700-7-34	1-7/8"	1-1/2"	1-1/4"	Euclid E-943
	700-7-35	2-3/4"	1-1/2"	2-1/2"	Euclid E-535
	700-7-37	2-1/8"	1-1/2"	1"	Euclid E-2361 Includes (2) E-1314 Used in Kits 700-7-9 & 700-7-249
	700-7-61	2"	1-5/8"	1-15/16"	Euclid E-2670 Used in Kits 700-7-9, 700-7-248, & 700-7-249
	700-7-62	1-7/8"	1-5/8"	7/8"	Euclid E-1567 Used in Kits 700-7-169 & 700-7-245
	700-7-64	2-7/8"	1-19/32"	2-1/2"	Euclid E-1571 Used in Kit 700-7-8 Includes Grease Zerk
	700-7-65	1-7/8"	1-1/2"	2"	Euclid E-661
	700-7-67	2-15/32"	1-1/2"	1-3/4"	Euclid E-2102
	700-7-68	2-1/2"	1-19/32"	1-1/2"	Euclid E-1577A Used in Kits 700-7-169 & 700-7-245
	700-7-205	2"	1-5/8"	1-3/16"	Euclid E-2690A Used in Kit 700-7-303

Bracket	Part No.	Application & Notes
	700-7-36	Euclid E-603 Early Model Meritor Axles Use with 700-7-35 Bushing
	700-7-219	Fruehauf ACD-2282 Use with 700-7-68 Bushing
	700-7-227	Euclid E-1318A Meritor A-3105-V-282 Used in Kits 700-7-7 & 700-7-248

Cam Washers, Lock Rings & Seals

WASHERS

Part No.	Replaces	O.D.	I.D.	Thickness	Note
700-7-40	Euclid E-581	2-1/4"	1-17/32"	0.032	Used on 1-1/2" Dia. Cam Shafts
700-7-41	Euclid E-580	2-1/4"	1-17/32"	0.06	Used on 1-1/2" Dia. Cam Shafts End Washer on Pro-Par Cam Shafts
700-7-94	Euclid E-564	2"	1-17/32"	0.05	Used with Meritor Cam Shaft Repair Kits
700-7-121	Euclid E-1565	2-3/8"	1-41/64"	0.059	Used with Pro-Par Cam Shaft Repair Kits
700-7-144	Euclid E-2411A	2-1/4"	1-5/8"	0.032	
700-7-174	Euclid E-3471	2-1/2"	1-5/16"	0.062	
700-7-96	Euclid E-656	3-7/8"	1-1/2"	1/16"	Used on 1-1/2" Dia. Cam Shafts



LOCK RINGS

Part No.	Replaces		I.D.	Thickness	Note
700-7-38	Euclid E-526		1-31/64"	1/16"	Used on 1-1/2" Dia. Cam Shafts
700-7-72	Euclid E-1569		1-1/2"	1/16"	Used on 1-5/8" Dia. Cam Shafts



SEALS

Part No.	Replaces	O.D.	I.D.	Thickness	Note
700-7-39	Euclid E-1416A	1-7/8"	1-1/2"	1/4"	Used on 1-1/2" Dia. Cam Shafts
700-7-73	Euclid E-654	2-1/16"	1-1/2"	1/4"	
700-7-178	Euclid E-2405	2"	1-5/8"	1/4"	Used in 700-7-61 Bushing



Manual Slack Adjusters



17-A23-100
10-Spline; 1-1/2"
5", 6", & 7" Drilling



17-A23-101
28-Spline; 1-1/2"
5" & 6" Drilling



17-A23-112
28-Spline; 1-1/2"
5-1/2" Drilling



17-A23-66B
37-Spline; 1-5/8"
6" Drilling



Rubber Boot
RW-2260S1111



Guide Pawl
RW-R801700



Clevis Pin
RW-19X1084



1/4" Pin
RW-19X127

Automatic Slack Adjusters

RW-R801041
10-Spline; 1-1/2"
5-1/2" Drilling

RW-R801042
10-Spline; 1-1/2"
6" Drilling

RW-R801003
24-Spline; 1-1/4"
5-1/2" Drilling

RW-R801072
28-Spline; 1-1/2"
5-1/2" Drilling

RW-R801073
28-Spline; 1-1/2"
5-1/2" Drilling

RW-R801074
28-Spline; 1-1/2"
6" Drilling

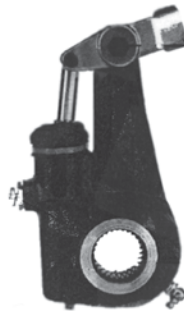

MERITOR

RW-R801102
37-Spline; 1-5/8"
6" Drilling



Clevis Kit
RW-R810019
Kit Includes:
RW-19X1084 Clevis Pin
RW-19X127 1/4" Pin



**Slack Adjuster Kit
(Minor)**
RW-KIT963

Automatic Slack Adjusters

GUNITE



Clevis Kit
GU-AS3000

GU-AS1032

10-Spline; 1-1/2"
5-1/2" Drilling

GU-AS1041

28-Spline; 1-1/2"
6" Drilling

GU-AS1043

37-Spline; 1-5/8"
5-1/2" Drilling

GU-AS1033

10-Spline; 1-1/2"
6" Drilling

GU-AS1040

28-Spline; 1-1/2"
5-1/2" & 6-1/2" Drilling

GU-AS1044

37-Spline; 1-5/8"
6" Drilling

CREWSON BRUNNER

with Autocheck



CB-41100

10-Spline; 1-1/2"
5-1/2" Drilling

CB-42100

28-Spline; 1-1/2"
5-1/2" Drilling

CB-42106

28-Spline; 1-1/2"
6" Drilling

CB-41106

10-Spline; 1-1/2"
6" Drilling

CB-22153

28-Spline; 1-1/2"
5" & 6" Drilling
Curved Arm; 12-1/4" Brakes

CB-43106

37-Spline; 1-5/8"
6" Drilling

BENDIX



BX-065174

28-Spline; 1-1/2"
5-1/2" Drilling

BX-065176

28-Spline; 1-1/2"
6" Drilling

Automatic Slack Adjusters

HALDEX



TRAILER

HA-400-10216

10-Spline; 1-1/2"
6" Drilling

HA-400-10211

28-Spline; 1-1/2"
5-1/2" Drilling

HA-400-10212

28-Spline; 1-1/2"
6" Drilling

HA-400-10305

28-Spline; 1-1/2"
6" Drilling
12-1/4" Brakes

HA-400-10213

37-Spline; 1-5/8"
5-1/2" Drilling

HA-400-10214

37-Spline; 1-5/8"
6" Drilling

TRAILER SELF-SET

HA-400-20215

10-Spline; 1-1/2"
5-1/2" Drilling

HA-400-20211

28-Spline; 1-1/2"
5-1/2" Drilling

HA-400-20213

37-Spline; 1-5/8"
5-1/2" Drilling

STEER AXLE

HA-400-10001

10-Spline; 1-1/4"
5-1/2" Drilling

HA-400-10004

24-Spline; 1-1/4"
5-1/2" Drilling

HA-400-10008

28-Spline; 1-1/2"
5-1/2" Drilling

DRIVE AXLE

HA-400-10142

10-Spline; 1-1/2"
5 & 6" Drilling

HA-400-10143

10-Spline; 1-1/2"
5-1/2" & 6-1/2" Drilling

HA-400-10155

10-Spline; 1-1/2"
5-1/2" Drilling
KW-8 Bag Air Ride

HA-400-10140

28-Spline; 1-1/2"
5" & 6" Drilling

HA-400-10141

28-Spline; 1-1/2"
5-1/2" & 6-1/2" Drilling

HA-400-10146

28-Spline; 1-1/2"
5-1/2" & 6-1/2" Drilling

HA-400-10144

28-Spline; 1-1/2"
6" Drilling
Mack Truck

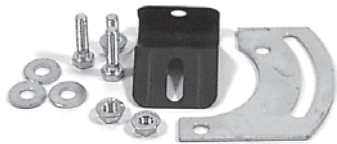

Bracket Assembly

HA-427-10431



Stud/Nut/Bushing

HA-427-10558



Anchor Bracket

HA-427-10563

Metal Dust Shields

For 16-1/2" X 7" Brakes
(one wheel application)



7-A2-51

Used on cast spiders
Replaces Euclid E-886

RW-R009095

Used on cast spiders

Plastic Dust Shields

(one wheel application)

700-7-228

5" Round Axle



700-7-229L

700-7-229R

5" Square Axle

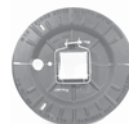

Axle Nuts & Washers



Outer Axle Nut

700-7-13

Thread 2-5/8"-16

Replaces:
Meritor 1227-B-7596
Euclid E-572



Inner Axle Nut

700-7-11

Thread 2-5/8"-16

Replaces:
Meritor 1227-C-549
Euclid E-540



Lockwasher

700-7-12

2-41/64" I.D.

3-7/8" O.D.

Replaces:
Meritor 1229-V-1660
Euclid E-573



Lockwasher

RW-R000573

2-41/64" I.D.

3-7/8" O.D.

Replaces:
Euclid E-3008
Replacement Set Screw:
RW-1199K3859

REPLACEMENT SPINDLE NUT & WASHER FOR FRUEHAUF PRO-PAR AXLES



Spindle Washer

700-7-15

3-1/2" I.D.

5-1/16" O.D.

x .255 Thick

Replaces:
Fruehauf AXA-0408-1
Euclid E-1561



Spindle Nut

700-7-14

3.480-12 THD

x 4-3/4" AF

Replaces:
Fruehauf ACE-8510-1
Euclid E-2550



Axle Nut Kit for TP Series Axles

RW-KITSTPN

3-1/2" Spindle



STEMCO™
PRO-TORQ®
ADVANCED AXLE SPINDLE NUTS

SM-447-4743
Standard HM Trailer

SM-447-4723
Pro-Par Trailer



Spindle Nut Wrench

50-24J-3

8-Point

3-3/8" & 3-7/8" Openings

Replaces:
Meritor 32560000
Euclid E-844



BEARINGS

Industry Number	Timken	Hyatt
567	TK-567	
580	TK-580	BG-580
582	TK-582	
593	TK-593	
594A	TK-594A	BG-594A
598A	TK-598A	BG-598A
663	TK-663	BG-663
665A	TK-665A	
3782	TK-3782	
212047	TK-HM212047	BG-HM212047
212049	TK-HM212049	BG-HM212049
218248	TK-HM218248	BG-HM218248
506310	TK-HH506310	
506348	TK-HH506348	
518445	TK-HM518445	BG-HM518445



RACES

Industry Number	Timken	Hyatt
563	TK-563	
572	TK-572	BG-572
592A	TK-592A	BG-592A
653	TK-653	BG-653
3720	TK-3720	
212011	TK-HM212011	BG-HM212011
218210	TK-HM218210	BG-HM218210
518410	TK-HM518410	BG-HM518410

BEARING / RACE SETS



Part No.	Set Consists of (1) Each:
TK-401	Timken 580 / 572
TK-403	Timken 594A / 592A
TK-405	Timken 663 / 653
TK-406	Timken 3782 / 3720
TK-413	Timken HM212049 / HM212011
TK-414	Timken HM218248 / HM218210
TK-415	Timken HM518445 / HM518410

Oil Seal Interchange

STEMCO	NATIONAL		CR		TRISEAL MVP	DANA	
VOYAGER/GUARDIAN	STANDARD	FIVE STAR	SCOTSEAL	SCOTSEAL PLUS	UNITIZED	OUTRUNNER	DANA
Trailer Axle Oil Seals							
307-0744	370037A		43752	43753	65298U		853
373-0113	370036A	380036A	40136	40133	65261U	301	850
373-0123	370065A	380065A	42623	42622	65262U	302	851
373-0143	370025A	380025A	46305	46304	65060U	303	859
Front Axle Oil Seals							
382-8034	370012A		36285		65291U		
383-0136	370001A	380001A	35066	35059	65263U	305	847
383-0139	370033A*		39988*	39977*	65294U*		
383-0153	370124A		44922	44919	65000U		855
383-0156	370131A	380131A	45103	45102	65078U		857
383-0164	370048A	380048A	43764	43763	65092U		863
	370018A	380018A	32470		65116U		
	*Use with adapter AR12		*Use with adapter 455031	*Use with adapter 455031	*Use with adapter 67038		
Drive Axle Oil Seals							
309-0903	370022A		45099	45097	65270U		856
309-0915	370024A		38750		65024U		
309-0935	370047A	380047A	34387	34386	65111U		
309-0960	370005A		48000	48001	65165U	308	860
309-0964	370021A		45160	45158	65172U	307	858
309-0970	370006A		47699		65283U		
392-0148	370069A		52658		65030U		
393-0104	370031A	380031A	42672	42671	65071U		852
393-0112	370023A	380023A	38780	38799	65024U	306	849
393-0112	370023A	380023A	38780	38779	65152U	306	849
393-0173	370003A		47697	47695	65156U	304	861
	370106A		42550		65027U		
	370019A		43861	43860	65184U		854
	370033A		38709		65275U		

STEMCO	NATIONAL	CR	TRISEAL MVP	DANA OUTRUNNER
TRAILER	TRAILER	TRAILER	TRAILER	TRAILER
SM-307-0713	NA-370025A	CR-40136	TS-65060U	DA-850
SM-307-0723	NA-370036A	CR-42623	TS-65262U	DA-851
SM-307-0743	NA-370065A	CR-42627	TS-70561	DA-859
SM-307-0744	NA-376590A	CR-46300	TS-70596	
SM-372-7015	NA-380025A	CR-46305	TS-70598	DRIVE AXLE
SM-372-7062	NA-380036A			DA-849
SM-372-7097	NA-380065A	DRIVE AXLE	DRIVE AXLE	DA-861
SM-372-7098		CR-47692	TS-65156U	
SM-372-7099	DRIVE AXLE	CR-47697	TS-70799	FRONT AXLE
SM-373-0144	NA-370003A			DA-847
	NA-370022A	FRONT AXLE	FRONT AXLE	DA-863
DRIVE AXLE	NA-370031A	CR-35066	TS-69697	
SM-309-0973	NA-380003A	CR-43764	TS-69699	
SM-392-9094	NA-380023A			
SM-392-9099				
SM-392-9112	FRONT AXLE			
SM-392-9131	NA-370001A			
	NA-370131A			
FRONT AXLE	NA-380001A			
SM-308-0836				
SM-382-8036				

Stemco Hub Caps, Gaskets, Window Kits, & Vent Plugs

Hub Caps				Gaskets	Window Kits	Vent Plugs
SM-300-4009 (Bulk Pack)	SM-340-4075	SM-342-4339	SM-343-4350	SM-330-3009	SM-359-5912	SM-359-5915
	SM-340-4095	SM-343-4009	SM-347-4009	SM-330-3024	SM-359-5992	SM-359-5990
SM-340-4009	SM-340-4195	SM-343-4013	SM-347-4013	SM-330-3067	SM-359-5995	SM-359-6124
SM-340-4013	SM-340-4249	SM-343-4024	SM-347-4075	SM-330-3107	SM-359-5999	
SM-340-4019	SM-340-5096	SM-343-4075	SM-347-4195	SM-330-3118	SM-359-6095	
SM-340-4024	SM-340-5097	SM-343-4095	SM-348-4009	SM-330-3122	SM-359-6117	
SM-340-4046	SM-342-4009	SM-343-4195	SM-640-0001			
SM-340-4059	SM-342-4075	SM-343-4249	SM-640-0003			

Misc. Hub Caps, Gaskets & Plugs

Part No.	Description		
CR-1343	6-Hole	5-1/2" Bolt Circle	Type TP1
CR-1643	6-Hole	5-1/2" Bolt Circle	Type TF8
CR-1644	6-Hole	5-1/2" Bolt Circle	Type TF8
CR-1743	6-Hole	5-1/2" Bolt Circle	Type H3

Chicago Rawhide Hub Caps



Side Hole Plug 8-6-85

Part No.	Description		
700-101-89	5-Hole	5-1/2" Bolt Circle	Lexan Hubo Mount
700-101-88	6-Hole	5-1/2" Bolt Circle	Lexan Hubo Mount
TS-64009S	6-Hole	5-1/2" Bolt Circle	
700-8-35	Universal Hub Cap Gasket (Replacement for Stemco 330-3067)		

Misc. Hub Caps & Gasket



Hubcap Mounting Bolt with Washer

700-50-18
5/16"-18 x 7/8" Long



Part No.	Description	Replaces Fruehauf:
700-8-5	Lexan Hub Cap	ACC 07538900
700-8-6	O-Ring	AXA 00484001
700-8-7	Top Oil Plug	
700-101-90	Lexan Hub Cap, Hubodometer Mounting	

Pro-Par Replacements

Hubodometer Mounting Brackets

Veeder-Root Mounting Brackets

VR-325614-101

For drive-axle applications

VR-325614-012

For over-hub-cap applications

Stemco Mounting Brackets

Part No.	Bolt Circle Diameter	Stud Size	Height	Style
SM-610-0006	7"	5/8"	1-11/16"	A
SM-610-0007	7"	3/4"	1-11/16"	A
SM-610-0011	5-1/4" - 7-3/4"	1/2"	1-3/4"	Universal Mount
SM-610-0024	5-1/2"	5/16"-18 Thread	4-1/2"	Over Hub Cap
SM-610-0065	5-1/2"	5/16"	3-1/2"	A -- Fits over 4009 Hub Cap
SM-610-0085	5-1/2"	5/16"	4"	

To measure bolt circle diameter:
(on axles with an even number of studs)

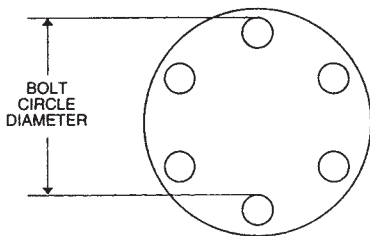

Style A

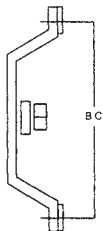

Universal Mount

Can be assembled in minutes to fit most drive axles. The Standard Kit fits 5 1/2" to 7 3/4" bolt circles and 1/2" stud size.

Part No. 610-0011

- 1 - Angles
- 2 - Strap
- 3 - Washer
- 4 - Nut
- 5 - Rivets

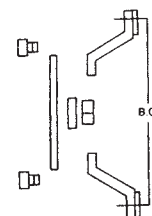

Hubodometers



Veeder-Root

Part No.	Description
VR-777717-475	475 Tire Revolutions equal 1-Mile
VR-777717-490	490 Tire Revolutions equal 1-Mile
VR-777717-494	494 Tire Revolutions equal 1-Mile
VR-777717-500	500 Tire Revolutions equal 1-Mile
VR-777717-510	510 Tire Revolutions equal 1-Mile
VR-777717-514	514 Tire Revolutions equal 1-Mile
VR-777717-520	520 Tire Revolutions equal 1-Mile
VR-777717-525	525 Tire Revolutions equal 1-Mile
VR-777717-572	572 Tire Revolutions equal 1-Mile
VR-777717-676	676 Tire Revolutions equal 1-Mile



Stemco

Part No.	Tire Size			
	SM-650-0587	10.00 - 22	11 - 24.5	
SM-650-0593	11.5 - 20	11.00 - 20	11.00R20	12 - 22.5
	12.5 - 22.5	12.5R22.5	12.75R22.5	12R22.5
	14180R20	365/70R22.5	365/80R20	
SM-650-0598	10.00 - 20	11 - 22.5	15 - 22.5	15R22.5
SM-650-0601	10.00R20	315/75R22.5	9.00 - 20	10 - 22.5
	11R22.5	13/80R20	275/80R24.5	285/75R24.5
	295/80R22.5	295/85R22.5		
SM-650-0605	12.5R20			
SM-650-0608	9.00 - 20	10 - 22.5	10R22.5	275/80R22.5
SM-650-0610	10.00/90R20	275/80R22.5	295/75R22.5	315/70R22.5
	9.00R20			
SM-650-0619	11/70R22.5			
SM-650-0626	10.00 - 15	255/70R22.5	37X12.50R16.5	