



DEXTER BRAKE ACTUATION SYSTEMS

DEXTER PREDATOR SERIES BRAKE ACTUATION SYSTEMS

Dexter Axle has the Predator Series line of brake actuation systems, the **Predator DX2**. This model utilizes a patented deceleration sensor for smooth, proportional braking and can power up to four electric brakes. Features include a digital LED that displays voltage output to the brakes and assists with leveling set-up, numeric gain settings, independent manual override for full braking power, short circuit protection, and a seven year product warranty.



Part No. 058-008-00



DEXTER HUB & DRUMS

Part No. 008-174-05

5 spoke Hub & Drum
-stud only. 12" x 2".
Grease application,
6000 lb. rating.



Part No. 008-247-05

5 spoke Hub & Drum
-stud only. 5-4.5 BC.
Grease application,
3500 lb. rating. 10" x 2-1/4".



Part No. 008-201-09

6 hole Hub & Drum
Assembly. 6-5.5 BC.
5200 lb. rating. 12" x 2"



Part No. 008-248-05

5 spoke idler hub only.
5-4.50 BC.
1/2"-20 3500 lb. rating.



Part No. 008-219-04

8 on 6.5 Hub & Drum
Assembly. 12" x 2"
Grease Application,
6000 lb. rating



Part No. 008-249-07

5 spoke Hub & Drum
Assembly. 10" x 2-1/4".
5-5.00 BC.
3500 lb. rating.



DEXTER TRAILER SPRINGS

Part No. 072-023-00 (double eye)
3 leaf, 25" length, 1,500 lb. capacity

Part No. 072-042-00 (double eye)
4 leaf, 25" length, 1,750 lb. capacity

Part No. 072-027-00 (double eye)
6 leaf, 25" length, 3,500 lb. capacity

Part No. 072-073-00 (double eye)
5 leaf, 25" length, 3,000 lb. capacity

Part No. 072-032-00 (slipper)
5 leaf, 26" length, 3,600 lb. capacity

Part No. SP35427 (double eye)
4 leaf, 28" length, 1,750 lb. capacity

When replacing worn or broken springs,
your worn spring will be longer than a new spring due to wear.



**slipper -
spring width 2.00"**



**double eye -
spring width 1.75"**

DEXTER WHEEL SEALS

Part No. 010-036-00
2.25 x 3.37 D-Lip Grease Seal
fits 12"x2" hub (after '98)

Part No. 010-003-00
1.23 x 1.98 S-Lip Seal

Part No. 010-040-00
1.938 x 2.51 Seal
fits 12x2 MHU hub



Part No. 010-060-00
1.50 x 1.98 D-Lip Grease Seal
fits 7" hub

Part No. 010-010-00
2.125 x 3.376 Oil Seal
(w/.468 double lip)

Part No. 010-051-00
2.87 x 3.88 Oil Seal
fits 9k and 10k GD hub/drum

Part No. 010-063-00
2.25 x 3.38 Oil Seal
fits 7.2k and 8k drums

Part No. 010-019-00
1.72 x 2.56 D-Lip Seal
fits 10"x2-1/4" hub.

Part No. 010-056-00
3.125 x 4.506 Oil Seal
fits 10k-15k HD hubs.



TIRE AND WHEEL ASSEMBLIES

Part No. A32395

Tire&Wheel
ST205/75R-15
5 hole-4.5,
150 lb. rating LRC
White Spoke Wheel



Part No. A32153

Tire & Wheel
ST205/75R-14
5 hole-4.5,
1,760# rating LRC
White Spoke Wheel



Part No. A30060

Tire & Wheel-
5 hole-4.5
4.80x8, spoke
745# rating LRC
White Conventional



Part No. A32673

Tire & Wheel
ST225/75R-15
6 hole-5.5,
2,450# rating
White Spoke Wheel



TIRE AND WHEEL ASSEMBLIES



Part No. A30040

Tire & Wheel-
4 hole-4.0
4.80x8, spoke
745# rating LRC
White Conventional



DEXSTAR WHEELS AND RIMS

Part No. 17-142-12

14 x 5.5, white 8 spoke
Bolt circle-5 hole-4.5
Capacity-1865@50psi



Part No. 17-243-14

16 x 6, bright white 8 spoke
Bolt circle-6 hole-5.5
Capacity-3040@80psi

Part No. 17-144-12

15 x 6 white 8 spoke
Bolt circle-6 hole-5.5
Capacity-2600@75psi

Part No. 17-293-14

16 x 6, bright white mini-mod
Bolt circle-8 hole-6.5
Capacity-3750@110psi

Part No. 17-149-12

15 x 6 white 8 spoke
Bolt circle-5 hole-4.5
Capacity-2050@75psi



Part No. 17-157-25

16.5 x 6.75, grey dual
Bolt circle-8 hole-6.5
Capacity-3000@80psi

Part No. 17-162-14

16x6, bright white 8 spoke
Bolt circle-8hole-6.5
Capacity-3750@110psi

Part No. 17-279-25

16 x 6 grey dual
Bolt circle-8 hole-6.5
Capacity-3000@110psi

Part No. 17-189-12

13 x 4.5 white 8 spoke
Bolt circle-5 hole-4.5
Capacity-1660@65psi



Part No. 17-153-65

16 x 6, black conventional
Bolt circle-8 hole-6.5
Capacity-3750@110psi

Part No. 17-053-25

14.5 x 6., grey rim,
demountable
Capacity-3100@100psi





DEXTER BRAKE ASSEMBLIES - ELECTRIC AND HYDRAULIC



Part No. K23-026-00 (LH)
Part No. K23-027-00 (RH)
 10 X 2-1/4, 4 hole, Electric Brake, 3500 lb.

Part No. K23-342-00 (LH)
Part No. K23-343-00 (RH)
 Hydraulic, free backing, 12" x 2".

Part No. K23-438-00 (LH)
Part No. K23-439-00 (RH)
 12-1/4 x 4, Electric Brake, 10000 lb.

Part No. K23-105-00 (LH)
Part No. K23-106-00 (RH)
 12 x 2, 5 hole, Electric Brake, 6000 lb.
 Also available as 023-105-09, LH 9-hole.
 Also available as 023-106-09, RH 9-hole.

Part No. K23-344-00 (LH)
Part No. K23-345-00 (RH)
 Hydraulic, free backing, 10 X 2-1/4

Part No. K23-446-00 (LH)
Part No. K23-447-00 (RH)
 12-1/4 x 5, Electric Brake, 15000 lb.

Part No. K23-180-00 (LH)
Part No. K23-181-00 (RH)
 12 x 2, Electric Brake, 7000 lb.



Part No. K23-434-00 (LH)
Part No. K23-435-00 (RH)
 12-1/4 x 3-3/8, 4 hole,
 Electric Brake, 8000 lb.

Part No. K23-450-00 (LH)
Part No. K23-451-00 (RH)
 12-1/4 x 3-3/8, Electric Brake,
 9-10000 lb.

DEXTER BRAKE DRUMS, BRAKE SHOES, AND HUBCAPS

DRUMS

12.25 X 4, 8 hole, 7.5 bolt circle, 10,000 lb.
Part No. 009-027-01

12.25 X 5, 8 hole, 7.5 bolt circle. 12-15,000 lb.
Part No. 009-028-01

12.25 X 3-3/8, 8 hole, 9-10,000 lb.
Part No. 009-044-01



BRAKE SHOE & LINING

12.25 X 4, Air.
Part No. 040-164-01

12.25 X 5, Air.
Part No. 040-165-01



12.25 X 7.5, Air PQ.
Part No. 040-320-01



12.25 X 4, Air PQ, 10, 000 lb.
Part No. 040-321-01

12.25 X 5, Air PQ, 12-15, 000 lb.
Part No. 040-322-01

BRAKE SHOE & LINING

For 10 x 2-1/4 **Hydraulic brakes**
Part No. K71-267-00

For 10 x 2-1/4 **Electric brakes**
Part No. K71-047-00

For 12 x 2 **Brakes**
Part No. K71-048-00



HUBCAP KITS

Part No. K71-038-00
 Oil cap-O-Ring and Plug kit, 6-8,000 lb
 screw-in and 9,000 lb prior to '89.

Part No. K71-148-00
 Oil cap, O-Ring and Plug kit, 10-15,000 lb
 screw-in and 9,000 lb prior to '89.



Part No. K71-317-00
 Grease cap and plug kit for 12"x2" hub,
 5 and 6 bolt. E-Z Lube®

Part No. K71-319-00
 8 bolt. E-Z Lube®

Part No. K71-315-00
 7", 10"x1.5" & 10"x2-1/4" hub, E-Z Lube®

Part No. K71-320-00 = E-Z Lube® Plug only



Chrome

**DEXTER MAGNET KITS, CYLINDERS, SUSPENSION PARTS & MISC.****MAGNET KITS****Part No. K71-104-00**

For 10 x 2-1/4

**Part No. K71-105-00**

For 12 x 2 6,000 lb.

Part No. K71-125-00

For 12 x 2 7,000 lb.

Part No. K71-375-00For 12-1/4 x 3-3/8 8,000 lb.
electric brakes (after 6/92)
Used with actuating lever kit
047-123-06 or 047-123-05.**Part No. K71-376-00 (yellow wire)**For 12-1/4 x 3-3/8 9-10,000 lb.
or 12-1/4 x 4 10,000 lb.
electric brakes (after 6/92)
Used with actuating lever kit
047-123-06 or 047-123-05.**Part No. K71-377-00 (black wire)**For 12-1/4 x 5 12,000 lb.
electric brakes (after 6/92)
Used with actuating lever kit
047-123-24 or 047-123-23.**Part No. K71-378-00 (blue wire)**For 12-1/4 x 5 15,000 lb.
electric brakes (after 6/92)
Used with actuating lever kit
047-123-24 or 047-123-23.**Part No. K71-650-00**Electro Hydraulic Actuator
for axles equipped with
drum brakes. 1000 psi.**Part No. K71-651-00**Electro Hydraulic Actuator
for axles equipped with
disc brakes. 1000 psi.**BRAKE CYLINDERS****Part No. K71-337-00 (LH)**For 10 x 2-1/4 and 12 x 2 brakes.
Uni-servo, 1-1/8" diameter.**Part No. K71-338-00 (RH)**For 10 x 2-1/4 and 12 x 2 brakes.
Uni-servo, 1-1/8" diameter.**Part No. K71-365-00**Equalizer kit for
2" wide slipper springs
for 33.5" axle spacing.**Part No. K71-401-00**Suspension kit for 1-3/4"
wide double eye springs,
tandem axles.**Part No. K71-403-00**Suspension kit for 1-3/4"
wide double eye springs,
single axles**Part No. K71-411-00**Adjusting screw and spring for
12-1/4 x 2-1/2 electric brakes
and all 12-1/4 manual adjust brakes.**Part No. K71-418-00**Brake adjuster kit for one
12-1/4 x 3-3/8, 12-1/4 x 4
and 12-1/4x5 electric brake
with stamped backing plate.**Part No. K71-421-00**Brake spring kit for one
12-1/4 x 3-3/8, 12-1/4 x 4
and 12-1/4 x 5 electric brake
with stamped backing plate.



SPRING AXLE ORDER FORM FOR AXLES 2K THROUGH 8K

Axle Capacity:_____

Hub Face:_____

Spring Center:_____



| | | | | | | |
|----------------|------|----------|------------|-----------|--------------|-----------|
| Brakes: | Yes: | Electric | Hydraulic: | Uni-Servo | Free Backing | Duo-Servo |
| | No: | Flange | No Flange | | | |

| | | | |
|----------------------|----------|---------|--|
| Spindle Type: | Straight | 4" Drop | 6" Drop |
| | Grease | EZ Lube | Nev-r-lube (straight only) Cartridge size of Nev-R-Lube |

Bolt Pattern:

Hub Size (Idler 2k)

| | | | | |
|----------------|------|-------------|---------|-----------|
| Spring: | Yes: | Double Eye: | Length: | Capacity: |
| | No: | Slipper: | Length: | Capacity: |

| | | | | |
|----------------------|------|-------|-------------|-----------------------|
| Spring Mount: | Over | Under | Seats Loose | 1.75" wide 2" wide |
|----------------------|------|-------|-------------|-----------------------|

Hanger Kit:

Attaching Parts Kit:

-From Dexter- "Return Policy"

If due to a customer error....

Dexter generally does not accept return of axles and/or beam assemblies unless a special restocking charge has been agreed upon. The standard restocking charge for these items is 50%. Axles and beams are items that have been custom made to a specific order. This potentially, results in many components being scrapped. The customer will be responsible for freight incurred for the return.



HYDRAULIC BRAKE WHEEL CYLINDERS

Dexter Heavy Duty Axle Order Form 20,000 lb - 25,000 lb.

Axle Capacity: 1/2" Wall 5/8" Wall 3/4" Wall

Track Width: _____

Spring Center: _____

Air Brakes: 12-1/4x7-1/2 16-1/2x7 None

Hubs: 3 spoke 5-spoke 10 hole inboard 10 hole outboard None

Hub piloted option: yes no

Spindle type: Grease or Oil

Air Chambers: T30 service or 30/30 complete or None

Cam Length: Standard _____ or Other _____

Slack adjuster: Manual or Automatic or None

Abs: Complete (sensors, blocks, tone rings) or Sensor blocks w/ sensors or Blocks only

Dust shields: yes or no



-From Dexter- "Return Policy"
If due to a customer error.... Dexter generally does not accept return of axles and/or beam assemblies unless a special restocking charge has been agreed upon. The standard restocking charge for these items is 50%. Axles and beams are items that have been custom made to a specific order. This potentially, results in many components being scrapped. The customer will be responsible for freight incurred for the return.

HYDRAULIC BRAKE WHEEL CYLINDERS



Single End Cylinder

Part No. K71-337-00 (LH)
For 10 x 2-1/4 and 12 x 2 brakes.
Uni-servo, 1-1/8" diameter.



Typical Double End, Straight or Step Bored

Part No. K71-338-00 (RH)
For 10 x 2-1/4 and 12 x 2 brakes.
Uni-servo, 1-1/8" diameter.



Single-Ended
Wheel Cylinder uses one cup, piston, and dust boot.

Double-Ended
Wheel Cylinder uses two cups, pistons, and dust boots with the same size bore.

Part No. E-5407X (LH)
Single end reman cylinder
Part No. E-5408X (RH)
Single end reman cylinder

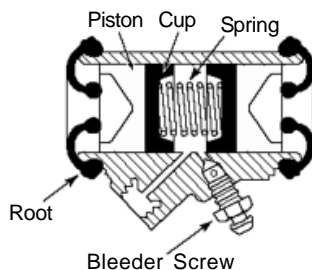
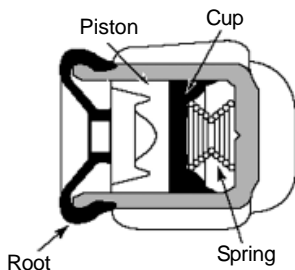

Part No. E-5413X (LH)
Reman expander cylinder
Part No. E-5414X (RH)
Reman expander cylinder



Part No. 033338
Wheel cylinder
Part No. 033400
Wheel cylinder





LIGHT DUTY TRAILER/TRUCK PRODUCTS

Part No. BH82000
 Combo Hitch & Hook
 w/ 2" Forged steel ball
 16,000 lb. max weight.



Part No. BH82516
 Combo Hitch & Hook
 w/ 2-5/16" Forged steel ball
 16,000 lb. max weight.

Part No. 1803005
 Straight ball mount..
 8" in length. 2" max drop,
 6,000 lb max weight. 2" shank,
 accepts 1" diameter shank towing balls.



Part No. 0091065
 Coupler, 2" ball x 3" channel.
 3,500 lb max weight.
 Can be bolted or welded to trailer frame.



Part No. 0090100
 Coupler, 2-5/16" adjustable coupler only
 12,000 lb max weight.
 Can be bolted to trailer frame.



Part No. PH20
 20-ton pintle hook. Drop forged steel.
 Black powder coat.
 40,000 lb max weight.
 Drawbar eye specs-2"-3" I.D. with
 1-1/4"-1-5/8" diameter section.



Part No. PM87
 Pintle Hook Mount.
 Continuous welds. Black powder coat finish.
 High and Low positioning.



Part No. BP200
 25-ton forged swivel-type pintle hook.
 Drawbar eye specs-2"-3" I.D. with
 1-1/4"-1-5/8" diameter section.



*Forged lashing rings made from
 C-1045 steel. 1/2" diameter ring.
 Includes weld-on mount, 2" wide.*

Part No. B38W 1/2" diameter ring.
 2-1/2"x2-3/8" 4,080 lb safe working load

Part No. B40 5/8" diameter ring.
 3"x 3" 6,130 lb safe working load

Part No. B46 3/4" diameter ring.
 3"x 3" 9,120 lb safe working load

Part No. B50 1" diameter ring.
 4"x 3" 15,586 lb safe working load



Part No. B16137
 Adjustable Eye Only
 3" I.D., 2" mounting.



Part No. BDL253
 Drawbar Lock. Zinc plated.
 Fits all 2-1/2"-3" lunette eyes.
 Accepts most 1/2" padlocks.



Part No. B03835SC
 Safety Chain w/ hook
 10,000 lb. max, 3/8" X 35"



Part No. BSC3835
 Safety Chain w/ hook
 15,000 lb max, 3/8" X 35"

Part No. VCGTX10 (10 ft.)
 Vernier heavy-duty adjustable
 locking control cables.

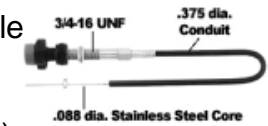

Part No. RO5B5X10 (10 ft.)
 Travel control cables, 5"

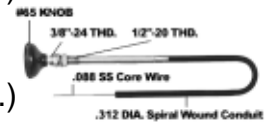

Part No. RO5B5X15 (15 ft.)

Part No. TGL3410ST
 Tailgate latch assembly with
 forged rod end and bracket.



Part No. B2373C
 Stake Pocket, straight, 1/4" steel,
 weld-on. 3-1/2" x 1-3/4"
 inside dimension. 4" depth.



Part No. 03020
 Heavy-duty rubber hood catch. 6".
Part No. 03015 (4-7/8")



Part No. 66064
 Snapper Pin
 A=1/4", B=2-1/2",
 C=2-1/2", D=2-49/64"

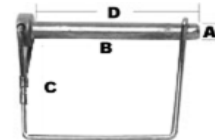

Part No. LB383
 Light Box. Black powder coat.

fits 6-1/2" oval



Part No. HPGS100
 Stem mount Gauge, 0-100 psi.
 Glycerin filled, 2-1/2" diameter.





TEKONSHA PRODUCTS

Part No. 90185

Prodigy Electronic Controller
Inertia-Activated Brake for 2 to 8 Axle Brake.
"Self-Leveling" ; Tekonsha's "Smart Control."
Limited Lifetime Warranty.

**Part No. 9030**

Voyager Electronic Brake Control
2 to 8 axle systems.
"The best valve you will find for
smooth and secure trailer braking.
5 year Limited Warranty.

**Part No. 2028**

Break Away Kit
for Single and Tandem Trailers.
Includes: Battery Case w/ mounting bracket,
2023X sealed 12V-5 Amp battery,
2024 DC-DC maintenance battery charger,
2130 Nylon breakaway switch.

**Part No. 90155**

Sentinel Electronic Brake
Control 2 to 6 Axle Systems.
"Ergonomic design" allows for
contour installation on the dash.
5 year limited warranty.

**Part No. 2024-07**

Maintenance Charger DC to DC 12 volt
"Provides maintenance-free assurance
that breakaway batteries are always fully
charged." Auto shut off to prevent overcharging.

**Part No. 2051 Battery Case**

Quick, easy four-bolt installation on any
flat surface. For use with self tapping
screws or similar fasteners.
Lockable heavy duty rust-proof polymer case protects
battery and charger from elements and corrosion.

**Part No. 2009-A**

Cable and Pin replacement
for 2009 switch.

**Part No. 2009-P**

Breakaway Switch, Metal.

**Part No. 2010-A**

Cable and Pin replacement
for 2010 switch.

**Part No. 2010-P**

Breakaway switch with
reinforced nylon case.
Weldable metal tab and coated 48" lanyard.
Rust and corrosion-free assures long life.
Silver contact points remain corrosion-free
for positive contact. Nylon pull pin can't
freeze up — assures positive actuation.

**Part No. 2026**

Break Away Kit less charger.
2026 Includes 2018 Polymer Battery Case
with A-Frame or Post Mounting Bracket;
2023 Rechargeable Sealed 12v 5-Amp/hr
Lead Acid Battery and Terminals;
2010 Nylon Breakaway Switch.

Part No. 2023X

Battery for 2028Kit. 12v, 5-Amp/hour
sealed lead acid battery for use with Shur
Set III Breakaway Systems on single,
tandem trailers equipped with
electric brakes. Battery requires
periodic recharging to maintain
optimum performance.

**Part No. 20015 Breakaway Kit**

Includes 2051 Lockable All Polymer Battery
Case with Flat Surface Mounting; 2023
Rechargeable Sealed 12v 5-Amp/hr Lead
Acid Battery And Terminals; 2024 DC-to-DC
Heavy Duty Quick / Maintenance
(Two Stage) Battery Charger;
2010 Nylon Breakaway Switch.





HAMMERBLOW PRODUCTS - Drop Legs and Couplers

Part No.182400

Drop Leg Jack. 12,000 lb. rating
Direct Weld Mount.
Standard Disc Foot
12.5" of Travel.



Part No.182800

Drop Leg Jack with Spring Return
12,000 lb. rating. Direct Weld Mount
Standard Disc Foot. 12.5" of Travel.



Part No.190704

Top Wind Jack. 7000 lb. rating
Direct Weld Mount. 15" of Travel.



Part No.190754

Side Wind Jack. 7000 lb. rating
Direct Weld Mount Drop Leg. 15" of Travel.



Part No.158109

Side Wind Swivel Jack, round.
2000 lb. rating. 10" Travel
Weld on Tubular mount included.



Part No.158151 15" travel

Part No.158452

Top Wind Swivel Jack, round.
2000 lb. rating. 15" Travel
Weld on Tubular mount included.



Part No.151401

Top Wind Swivel Jack, round.
2000 lb. rating. 10" Travel
Weld on retaining ring swivel included.

Part No.151101

Side Wind Swivel Jack, round.
2000 lb. rating. 10" Travel
Weld on retaining ring swivel included.

Part No. 1701480317 (170150)

Top Wind Swivel Jack, round.
5000 lb. rating. 15" Travel
No foot, no mount, painted outer tube, zinc inner.

Part No.178203

Side Wind Swivel Jack, round.
5000 lb. rating. 15" Travel
Weld on Tubular mount included.



Part No.198250

Side Wind Swivel Jack, round.
7000 lb. rating. 15" Travel
Weld on Tubular mount included.

Part No.178151

Top Wind Swivel Jack, round.
5000 lb. rating. 15" Travel
Weld on Tubular mount included.

Part No.178101

Top Wind Swivel Jack, round.
5000 lb. rating. 10" Travel
Weld on Tubular mount included.

Part No.1750290317

Top Wind A-Frame, round.
12.2" bracket to ground retracted.
5000 lb. rating. 15" Travel
Weld-on/bolt-on bracket.
Less wheel or base.



Part No.175000

12.25" bracket to ground retracted.

Part No.018173

Detachable Disc Foot, 150 series.



COLLAR-LOK™ COUPLERS

Part No.028382

3" square/rectangular tongue mount
5,000 lb. 16-1/4" length, 2" ball size.



FULL LINE OF HAMMERBLOW/BULLDOG JACKS AND COUPLERS ARE AVAILABLE!



BENDIX SEVERE DUTY DISC PADS



SEVERE DUTY PADS FOR HYDRAULIC DISC BRAKES

Engineered for superior stopping, high fade resistance, and long life. Formulated for school bus and other severe use vehicles.

| | | | |
|-------------------------------|-------|-----------------------------|------|
| Typical Frictional Properties | | Typical Physical Properties | |
| SAE J661a | | Gogan Hardness | 27 |
| Normal Friction | 0.330 | Specific Gravity | 3.10 |
| Hot Friction | 0.316 | Flexural Strength (Average) | |
| 400° F Wear Friction | 0.330 | | |

| Application | Part No. |
|--|---------------|
| Bendix 3.38" Single Piston | TPD184 |
| Bendix 2.60" Twin Piston (1st & 2nd designs) | TPD184 |
| Bendix 2.88" Twin Piston (1st & 2nd designs) | TPD225 |
| Dayton 2.50" Twin Piston | TPD224 |
| Dayton 2.88" Twin Piston | TPD236 |

BENDIX DISC BRAKE PAD SETS



PREMIUM OEM - Disc Brake Pads and Parts



Don't take a chance on • Pad separation • Poor mileage

- Disc Brakes Are Not Interchangeable Like Drum Brakes. •
- One set services one axle•

Advanced engineering allows Formula Blue® medium-duty disc pads to provide higher levels of performance and cost-effectiveness.

The 109 series friction material caters to a wide range of Class 6 & 7 vehicles.

Part No. E10901840
(BD184BX108) (E-D380-V)
 GMC, Ford, International. '79-'03
 2.60 Bendix Calipers.



Part No. E10902240
(BD224BX108) (E-D224-V)



Part. No. MKD769PREM
 Chevrolet, C4500 & C5500. '03-'05



Part No. MK224PREM (E-D224-S)
 GMC, Ford, International. '79-'03.
 2.50 Bendix Calipers.

Part. No. E10902250
(BD225BX108) (E-D225-V)

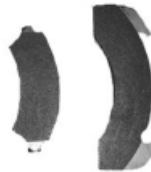

Part No. E10907860
(BD786BX108) (E-D786-V)

Part No. MK225PREM (E-D225-S)
 GMC, Ford, International. '90-'04
 2.88 Bendix Calipers.

Part No. MKD786 (E-D786-S)
 GMC, Ford, International.
 (multi-years)
 Bosch-Pin slider 73mm.



Part No. E10902360
(BD236BX108) (E-D236-V)
 GMC, Ford, International. ('84-'95)
 2.88 Bendix Calipers.

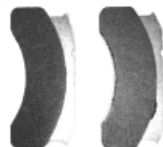

Part No. E10907861
(BD786ABX108)
Part No. MKD786A (E-D786A-S)
 Bosch-Pin slider 66mm.





SPRING BRAKES - BRAKE CHAMBERS - SERVICE CHAMBERS

Long Stroke Brake Chambers

Watch your brake chambers! Most new vehicles are now being equipped with long-stroke brake chambers. This allows more stroke than older models. You will find clamp type 16 and clamp type 20 long stroke chambers on the steering axles and clamp type 24 and clamp type 30 long stroke chambers on other axles. Some of the type 30 chambers allow a three-inch stroke.

A long stroke brake chamber can be identified by the raised inlets, embossed etching on the side of the chamber and/or a trapezoidal shaped I.D. tag indicating long stroke, and the maximum stroke allowed.

The key advantage of the extra stroke available from the actuator's unapplied position to full extension, is that it keeps brakes in adjustment longer, reduces out of adjustment citations and improves brake efficiency.

All VENDORS advise to never install long stroke and standard stroke chambers on the same vehicle. This can cause poor brake balance and timing.

When servicing these brake actuators, it is imperative that strict attention is paid to the components. These chambers have push rod stroke capabilities in excess of the standard 2.25" to 2.5" design.

(They are identified as " Long Stroke "- "LS"-or"3"stroke")

The components are unique, and include the following:

•service diaphragm •service housing •service push rod •complete piggyback

Long Stroke Brake Chambers Have Square Ports.

Long Stroke Chambers Provide 17% More Stopping Ability On A Hot Stop!!



Standard Stroke
w/ Round Ports



Long Stroke w/
Square Ports

Single chambers-service chambers also have the square ports.





SPRING BRAKES - BRAKE CHAMBERS

Haldex Gold Seal® is guaranteed with **four-year, unlimited mileage warranty coverage***. All the design features and benefits of Gold Seal add-up to save you time and money by reducing your maintenance and downtime expenses.

*See Haldex Warranty Policy Number L20221 for details.

HALDEX GOLD SEAL® SPRING BRAKE CHAMBERS

| PART No. | DESCRIPTION |
|----------|-------------|
| GC2424 | Type 24/24 |
| GC2430 | Type 24/30 |
| GC3030 | Type 30/30 |
| GC3036 | Type 30/36 |
| GC3636 | Type 36/36 |



HALDEX GOLD SEAL® PIGGYBACK CHAMBERS

| PART No. | DESCRIPTION |
|----------|-----------------------------------|
| GP2424 | Type 24/24 GP Gold Seal Piggyback |
| GP2430 | Type 24/30 GP Gold Seal Piggyback |
| GP3030 | Type 30/30 GP Gold Seal Piggyback |
| GP3036 | Type 30/36 GP Gold Seal Piggyback |

HALDEX GOLD SEAL® LONG STROKE SPRING BRAKE CHAMBERS

| PART No. | DESCRIPTION |
|----------|--------------------------------|
| GC3030L | Long Stroke Chamber Type 30/30 |
| GC2424L | Long Stroke Chamber Type 24/24 |

HALDEX GOLD SEAL® PIGGYBACK LONG STROKE CHAMBERS

| PART No. | DESCRIPTION |
|----------|-----------------------------------|
| GP3030L | Long Stroke Piggyback, TYPE 30/30 |
| GP2424L | Long Stroke Piggyback, Type 24/24 |



PIGGYBACK KITS- ALL BRANDS.
Kits Include Piggyback, diaphragm and clamp kit



| PART No. | DESCRIPTION |
|-----------|---|
| 1010453BX | Fleetcraft 30/30 Piggyback Kit. |
| 1010457BX | Fleetcraft 30/30 Long stroke Piggy Kit. |
| 3230008 | MGM 3" Long Stroke Piggyback TR3030LP3. |
| 3427008 | MGM Piggyback Kit, TR2424L. |
| 3429008 | MGM Piggyback Kit, TR2430L. |
| 3433008 | MGM Piggyback Kit, TR3036. |
| 5007610 | Bendix Type 30/30 Piggyback. |
| GP3030K | Haldex Gold Seal® 3030Piggyback Kit. |
| GP3030LK | Haldex Gold Seal® Long stroke 3030 Piggy Kit. |
| LP3030K | Haldex Life Seal® 3030Piggyback Kit. |
| LP3030LK | Haldex Life Seal® Long stroke 3030 Piggy Kit. |

Life Seal is the only actuator to maximize output force over an extended period. A unique patented power spring maintains high output force while increasing strength. The center tube guides the form-fit pressure plate, which stabilizes the spring coil through the full range of travel. This prevents contact with the spring housing and dramatically reduces coil clash.

With the advanced technology of Life Seal, Haldex offers the first, six-year, million-mile warranty.

*See Haldex Warranty Policy Number L20221 for details.

LIFESEAL™ BRAKE CHAMBERS

| PART No. | DESCRIPTION |
|----------|-----------------------------------|
| LC3030 | Type 30/30, Less Clevis |
| LC3030L | 3" Long Stroke Chamber Type 30/30 |



LIFESEAL™ SEALED PIGGYBACK CHAMBERS

| PART No. | DESCRIPTION |
|----------|-------------------------|
| LP3030 | TYPE 30/30 |
| LP3030L | Long Stroke, TYPE 30/30 |



MANY FEATURES make Fleetcraft Spring Brake Chambers durable and long-lasting!

- An OEM patented spring housing seal design.
- Permanently engraved/painted push rod stroke indicator.
- Precision weld push rod and plate attachment.
- A steel w/precision welded hub pressure plate.
- Aluminum die cast center section that is the thickest in the industry, and a precision ground mirrorplated center piston finish. *Wrap it up with a 3-year Warranty!*

FLEETCRAFT® SPRING BRAKE CHAMBERS LISTING

| PART No. | DESCRIPTION |
|----------|--|
| 1010447 | Type 30/30, Less Clevis |
| 1010448 | Type 30/30, Piggyback chamber |
| 1010449 | Type 30/30, Complete With Clevis |
| 1010450 | Type 24/24, Long stroke Complete with Clevis. |
| 1010451 | Type 30/30, w/12.5"rod for Intraax, w/o clevis. |
| 1010452 | Type 30/30, w/cut shaft 5.75".(7.25" to clevis.) |
| 1010456 | Type 30/30, Long Stroke(3"). |
| 1010459 | Type 30/30, 2.5" stroke, double clamp, tamper resistant. |



BRAKE CHAMBER (10" Push Rod)
For HENDRICKSON® INTRAAX AAT 23K, 25K, 30K



Part No. 3230551 (S24247-1) MGM 30/30, Std Long Stroke.

WARNING!

Do not attempt to remove or service the spring chamber clamp ring on any spring brake. The large spring in the spring chamber has extreme force which could cause serious bodily injury if it were suddenly released due to inadvertent removal of this clamp.



MGM SPRING BRAKES

"Tamper Resistant"

TR Model design prevents accidental disassembly of the power spring housing.

| Combo | Piggyback | | |
|----------|-----------|-------|--------|
| Part No. | Plus Kit | Size | Stroke |
| 3427051 | 3427008 | 2424L | 2.50 |
| 3429051 | 3429008 | 2430L | 2.50 |
| 3430051 | 3430008 | 3030 | 2.50 |
| 3433051 | 3433008 | 3036 | 2.50 |
| 3437051 | 3437001 | 3636 | 3.00 |



All units are furnished with a universal fully threaded rod which must be cut to the correct length.



*LTR-LP3 Model have a 6-yr. warranty.

•Piggyback Plus Kits include piggyback, clampband & service diaphragm.

Note: These model sized offered only in combination assemblies with MGM heavy duty weld-reinforced mounting base. Use these models to replace like (long stroke) brake chambers only.

MGM Model TR-TS Series -(30/30 combo 2.5" stroke)

"Full Epoxy Coated External Tube Breather System."

The power spring chamber is "sealed" against any contaminated and corrosive outside air because 100% of the air drawn in originates from the inside protected area of the service brake chamber. The result is an MGM spring brake that is CORROSION-FREE... proven in over 25 years of use on heavy vehicles of European origin equipped with MGM-Europa spring brakes. Same for the MGM Model LTR-T Series.



Combination Piggyback

| Size | Stroke | Part No. | Plus Kit |
|---------|--------|----------|----------|
| 3030LP3 | 3.00 | 3230051 | 3230008 |

TR-TS
30/30
Part No.
3531051
(severe svc.)



LTR-T
Part No.
3831051
(alum head)



TR-SB
Part No.
3431047
(low hold back)



Special Length Push-Rod, 3030 assembly - Part No. 3430551 (Also 1010451)

12" dimension from bottom face of service chamber to end of threaded push rod. Push rod diameter 5/8", threaded length 5". (Ex:-For transit, or Intraax suspensions.)



MGM SERVICE CHAMBERS & COMPONENTS

Part No. 1621901 Type C30L3 Stroke 3.00
Type 20, long stroke, w/ welded clevis. Sealed



Part No. 8017424 Type 24L3 Stroke 3.00"
Type 24, long stroke.



Part No. 1428001 Type C24L Stroke 2.50
Type 24, standard stroke.



Part No. 8017330 Type 30 Stroke 2.50"
Type 30, standard stroke.



Natural rubber blend with nylon fabric reinforcement. Good for extreme cold weather climates down to -65° F.

Part No. 1420001 Type C30L Stroke 2.50
Type 30, standard stroke.



Part No. 9019005P
Plug Kit for TR, TR-T, sizes 2024, 2424L, 2430L, 3024, 3030, TR-TS, sizes 2424L, 2430L, 3030



Part No. 1431001 Type C30L3 Stroke 3.00
Type 30, long stroke.



Part No. 9081001
Breather Tube for all MGM chambers with breather tube except: M3030B-T, M3036B-T, M3636B-T.





SERVICE CHAMBERS & COMPONENTS

HALDEX SERVICE CHAMBERS

•Fully Threaded Push Rod •Orange Alert Stroke Indicator •Piloting Dust Shield

| DESCRIPTION | PART NO. | STROKE |
|-------------|----------|--------|
| TYPE 9 | SC09 | 1.75" |
| TYPE 12 | SC12 | 1.75" |
| TYPE 16 | SC16 | 2.25" |
| TYPE 20 | SC20 | 2.25" |
| TYPE 24 | SC24 | 2.25" |
| TYPE 30 | SC30 | 2.50" |
| TYPE 36 | SC36 | 3.00" |



SC09, SC12,
SC16, SC20
have Step Housing.



SC24, SC30, SC36
have Flat Housing.



Part No. DP24L
Diaphragm type 24
2.25" & 2.50" stroke.

Part No. DP30
Diaphragm type 30
2.50" stroke.

Part No. DP30L
Diaphragm type 30
3.00" stroke.



Part No. CB30S1
Clamp Band Assembly
Type 30, Black.

FLEETCRAFT SERVICE CHAMBERS

- A patented spring housing seal design.
- Permanently engraved/painted push rod stroke indicator.
- Precision weld push rod and plate attachment. Less yoke assembly.

| DESCRIPTION | PART NO. | STROKE |
|-------------|----------|--------|
| TYPE 12 | 1036120 | 1.75" |
| TYPE 16 | 1036160 | 2.25" |
| TYPE 20 | 1036200 | 2.25" |
| TYPE 24 | 1036240 | 2.25" |
| TYPE 30 | 1011900 | 2.50" |



AIR CHAMBER CLAMP BOLTS

Bolt and Nut Assembly
Part No. NL1133

³/₈"-16 X 2³/₁₆".

Replaces:

Haldex 11M052 Bolt

11M051 Nut

MGM Kit 9003001



WE HAVE THE TYPE 30 SERVICE CHAMBERS
AVAILABLE IN DIFFERENT PRE-CUT SHAFT
LENGTHS - PART NO.'S 1011901/1011902/1011903.



Service Chamber Components

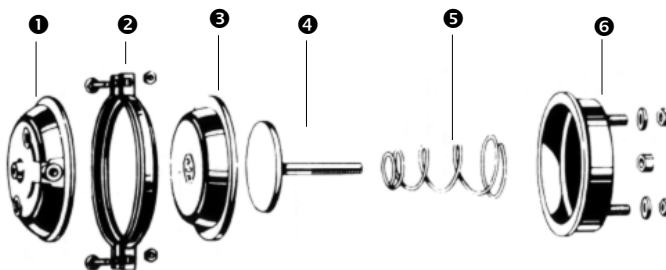

| Item | PART DESCRIPTION | CHAMBER SIZE | | | | | |
|------|-------------------|------------------------|---------|---------|---------|---------|---------|
| | | TYPE 9 | TYPE 12 | TYPE 16 | TYPE 20 | TYPE 24 | TYPE 30 |
| | | COMPONENT PART NUMBERS | | | | | |
| 1 | Cover Assembly | | | | | 1036242 | 1036302 |
| 2 | Clamp Band Kit | CB09 | CB12 | CB16 | CB20 | 1019248 | 1019308 |
| 3 | Diaphragm | 1018090 | 1018120 | 1018160 | 1018200 | 1018240 | 1018300 |
| 4 | Push Rod Assembly | | | | | 1036241 | 1036301 |
| 5 | Return Spring | | | | | | 1036304 |
| 6 | Non-Pressure Body | | | | | 1036243 | 1036303 |



SPRING BRAKE & SERVICE CHAMBER ACCESSORIES



YOKE ASSEMBLIES - FORGED

| PART No. | PIN SIZE | LENGTH | THREAD | CHAMBER SIZE |
|----------|----------|--------|---------|--------------|
| 1036450 | 1/2" | 1.88" | 1/2"-20 | 12,16,20 |
| 1036470 | 1/2" | 1.88" | 5/8"-18 | 20,24,30 |



— Length —

Complete with clevis pin and cotter pin.
Zinc and Dichromate plating.

| PART No. | PIN SIZE | LENGTH | THREAD | Chamber SIZE |
|----------|----------|--------|---------|--------------|
| CF1 | 1/2" | 1.81" | 1/2"-20 | 9,12,16 |
| CF3 | 5/8" | 2.50" | 5/8"-18 | 20,24,30 |



STAMPED YOKE ASSEMBLIES

Complete with clevis pin and cotter pin.
Zinc and Dichromate plating.



| CLEVIS PINS |
|----------------------------|
| 1/2" Pin Part No. 19100 |
| 5/8" Pin Part No. CP2 |



| PART No. | PIN SIZE | LENGTH | THREAD | Chamber SIZE |
|----------|----------|--------|---------|--------------|
| CS2 | 1/2" | 1.50" | 5/8"-18 | 20,24,30 |

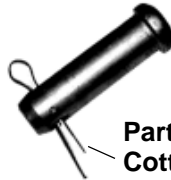

Part No. 1F-316
Cotter Pin

DUST BOOT

Plate and rubber boot for chambers with 4^{3/4}" mounting centers (Type 20, 24,30 & 36). Protects inside of service chamber.
Part No. 11M034



CAGING BOLT PLUG

For All Haldex Gold Seal Chambers except type 36.
Part No. RTP1



Part No. RTP2 (Midland Style)



SPRING BRAKE RELEASE STUD ASSEMBLY

For all spring brakes except 36 series.
Part No. RT1



Just the bolt:
Part No. 10043

DUST PLUG FOR 30/30 SPRING BRAKES.

Part No. 1036305



AIR CHAMBER CLAMP BOLTS Bolt and Nut Assembly

Part No. NL1133

3/8"-16 X 2^{3/16}".

Replaces:

- Haldex 11M052 Bolt
- 11M051 Nut
- MGM Kit 9003001
- Euclid Kit E2144



Part No. HW5 (5/8" Jam Nut)

SPRING BRAKE CHAMBER BRACKETS FOR AXLE MOUNTING

Universal Bracket for 5 Inch Round Axles 5/16" Thick. Can be used with spring brakes.
Part No. 2-139 (E2518A)



Universal Bracket for 5 Inch Round Axles 5/16" thick. Can be used with spring brakes.
Part No. E-631



Universal Bracket for Meritor 5 Inch Round Axles
Part No. 3299A5981 (E2681A)



Fruehauf "Pro-Par" Axle with 16-1/2" Brakes. Allows use of 5-1/2" or 6" Slack Adjusters. Sold as Set Only.
Part No. E-3781





FACTORY ASSEMBLED AIR HOSE ASSEMBLIES

- TYPE B
- Single Swivel
- Permanent Fittings
- Meets All SAE J1402 and DOT 106 Specifications

Hose Rack Part No. 700-17-460



HOSE END ADAPTORS
Changes NPTF end fitting sizes on hose assemblies.

| Hose I.D. | NPTF Size | Part No. |
|-----------|-----------|-----------------|
| 3/8" | 1/4" | N12306 |
| 3/8" | 3/8" | N12306G |
| 1/2" | 3/8" | N12306AG |

| 3/8" HOSE, 1/4-18 NPTF FITTINGS | | |
|---------------------------------|-----------|-----------|
| 16012 12" | 16028 28" | 16042 42" |
| 16014 14" | 16030 30" | 16044 44" |
| 16018 18" | 16032 32" | 16046 46" |
| 16020 20" | 16034 34" | 16048 48" |
| 16022 22" | 16036 36" | 16054 54" |
| 16024 24" | 16038 38" | 16060 60" |
| 16026 26" | 16040 40" | 16066 66" |
| | | 16072 72" |

| 3/8" HOSE, 3/8-18 NPTF FITTINGS | | |
|---------------------------------|-----------|-----------|
| 16614 14" | 16630 30" | 16644 44" |
| 16618 18" | 16632 32" | 16646 46" |
| 16620 20" | 16634 34" | 16648 48" |
| 16622 22" | 16636 36" | 16654 54" |
| 16624 24" | 16638 38" | 16660 60" |
| 16626 26" | 16640 40" | 16672 72" |
| 16628 28" | 16642 42" | |



RUBBER AIR BRAKE HOSE ASSEMBLIES:

- Both ends swivel.
- Minimum burst pressure of 900 PSI.
- Conforms to SAE J1402 specifications.
- Maximum operating pressure of 225 PSI.
- Operating temperature of -40°F to +200°F.

| Part No. | Hose Size | Fitting Size |
|-----------|-----------|--------------|
| 16420 20" | 3/8" | 3/8" |
| 16424 24" | 3/8" | 3/8" |
| 16426 26" | 3/8" | 3/8" |
| 16428 28" | 3/8" | 3/8" |
| 16432 32" | 3/8" | 3/8" |
| 16436 36" | 3/8" | 3/8" |

| Part No. | Hose Size | Fitting Size |
|-----------|-----------|--------------|
| 16444 44" | 3/8" | 3/8" |
| 16448 48" | 3/8" | 3/8" |
| 16452 52" | 3/8" | 3/8" |
| 16456 56" | 3/8" | 3/8" |
| 16466 66" | 3/8" | 3/8" |
| 16472 72" | 3/8" | 3/8" |



| Part No. | Hose Size | Fitting Size |
|-----------|-----------|--------------|
| 16810 10" | 7/16" | 3/8" |
| 16818 18" | 7/16" | 3/8" |
| 16824 24" | 7/16" | 3/8" |
| 16830 30" | 7/16" | 3/8" |
| 16832 32" | 7/16" | 3/8" |
| 16836 36" | 7/16" | 3/8" |

| Part No. | Hose Size | Fitting Size |
|-----------|-----------|--------------|
| 16842 42" | 7/16" | 3/8" |
| 16848 48" | 7/16" | 3/8" |
| 16854 54" | 7/16" | 3/8" |
| 16860 60" | 7/16" | 3/8" |
| 16872 72" | 7/16" | 3/8" |

| 7/16" HOSE, 3/8-18 NPTF FITTINGS | | |
|----------------------------------|-----------|-----------|
| 16314 14" | 16330 30" | 16344 44" |
| 16318 18" | 16332 32" | 16346 46" |
| 16320 20" | 16334 34" | 16348 48" |
| 16322 22" | 16336 36" | 16354 54" |
| 16324 24" | 16338 38" | 16360 60" |
| 16326 26" | 16340 40" | 16372 72" |
| 16328 28" | 16342 42" | 16384 84" |

BULK AIR BRAKE HOSE

Construction



- Tube: Black EPDM (Versigard)
- Reinforcement: 2-Spiral Synthetic
- Cover: Black EPDM (Versigard)
- Temperature Range
F & C: -40F to +200F (-40C to +93C)
- SAE Specifications: SAE J1402A
- DOT: FMVSS-106

3/8" I. D. HOSE

- 250 feet Part No. 1014307-250
- 50 feet Part No. 1014307-50
- 25 feet Part No. 1014307-25

1/2" I. D. HOSE

- 250 feet Part No. 1014310-250
- 50 feet Part No. 1014310-50
- 25 feet Part No. 1014310-25



REUSABLE AIR BRAKE HOSE FITTINGS



**FITTING ASSEMBLY
NPTF Male
Less Guard Spring**

For 3/8" Hose
1/4" NPTF Part No. 11903
3/8" NPTF Part No. 11904
1/2" NPTF Part No. 11905

For 1/2" Hose
3/8" NPTF Part No. 11804
1/2" NPTF Part No. 11805



**FITTING ASSEMBLY
With Spring Guard**

For 3/8" Hose
1/4" NPTF Part No. 11900
3/8" NPTF Part No. 11901
1/2" NPTF Part No. 11902

For 1/2" Hose
3/8" NPTF Part No. 11801
1/2" NPTF Part No. 11802



UNION ASSEMBLY

For 3/8" Hose - Part No. 11913
For 1/2" Hose - Part No. 11813



NUT

For Fitting Without Spring - 3/8" Hose
Part No. 11906



SPRING

3/8" Hose
Part No. 11911



BODY

For 3/8" Hose
1/4" NPTF - 11907
3/8" NPTF - 11908
1/2" NPTF - 11909



FERRULE

3/8" Hose: Part No. 11912
1/2" Hose: Part No. 11812

AIR BRAKE HOSE END REPAIR KITS

AIR BRAKE HOSE END FITTING KITS WITH SWIVEL

- Contains 2 fittings to equip one hose.
- Meets the requirements of DOT 106 and SAE J1402.
- Each kit contains two corrosion resistant brass and nylon fittings with swivel ends.
- Kits for both 3/8" and 1/2" hose available.

| Hose Size | NPTF Fitting Size | Kit Part No. |
|-----------|-------------------|--------------|
| 3/8" | 3/8" | 31402 |
| 3/8" | 1/2" | 31403 |

Press Fit Required

| Hose Size | NPTF Fitting Size | Kit Part No. |
|-----------|-------------------|--------------|
| 1/2" | 3/8" | 31305 |



FRAME NIPPLES

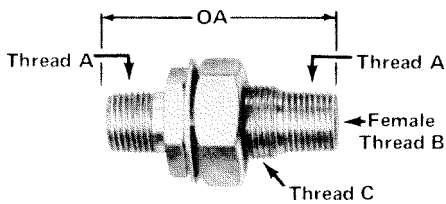

| Part No. | A | B | C | OAL |
|----------|-----------|-----------|----------|--------|
| 11300 | 1/2" NPTF | 1/4" NPTF | 1-14 UNS | 2-7/8" |

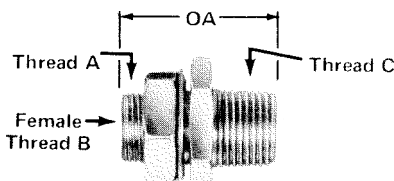

| Part No. | A | B | C | OAL |
|----------|-----------|-----------|-----------|----------|
| N11171B | 3/4-16 NF | 1/4" NPTF | 1/2" NPTF | 1-11/16" |
| 11315 | 1-14 UNS | 1/4" NPTF | 1/2" NPTF | 2-1/8" |
| 11304 | 1-14 UNS | 3/8" NPTF | 1/2" NPTF | 1-5/8" |

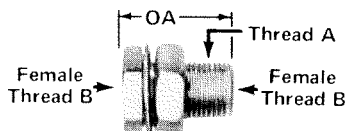

| Part No. | A | B | OAL |
|----------|-----------|-----------|--------|
| 11306 | 3/4-16 NF | 1/4" NPTF | 1-3/8" |
| 11307 | 1-14 UNC | 3/8" NPTF | 1-3/8" |



Frame Coupling with nylon tube fitting - Part No. S608 1/2" OD Tube x 3/8" NPTF, 1-15/16" OAL
Frame Coupling with nylon tube fitting - Part No. S609 3/8" OD Tube x 3/8" NPTF, 1-15/16" OAL



GLADHANDS

Anodized Gladhands

For use on aircoil, tractor and trailer 1/2" pipe port.

Part No. 12-006 (Service)

Part No. 12-008 (Emerg)

Part No. 12-010 (Univ)

PHILIPS



IRON GLADHAND

Lifetime iron body will not crack or break.

One piece construction.

Meets all applicable requirements of SAE J318.

1/2" NPTF port.

Part No.FC35031 Universal

Part No.FC35032 Emergency

Part No.FC35033 Service



STANDARD GLADHANDS

Aluminum with steel face.

1/2"-14 NPTF port.

| CONFIGURATION | Part No. |
|----------------------|----------------|
| Universal (No Color) | 1011450 |
| Emergency (Red) | 1011451 |
| Service (Blue) | 1011452 |



GLADHANDS - BRACKET MOUNT

40° ANGLE BRACKET MOUNT GLADHANDS

Available in both 3/8" and 1/2" port sizes Polarized and color coded in emergency and service configurations. Includes full face style gladhand seal.

| 3/8" Ports | | 1/2" Ports | |
|---------------|--------------|---------------|--------------|
| CONFIGURATION | PART No. | CONFIGURATION | PART No. |
| Service | 11440 | Service | 11444 |
| Emergency | 11441 | Emergency | 11445 |

Haldex

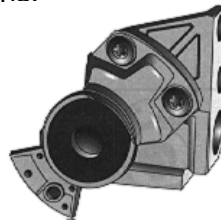

Filtered Gladhands

Heavy-Duty. Steel face is zinc yellow dichromate and aluminum body is chromate conversion coated for corrosion resistance. Internal filter comes installed to protect airline from contamination.

Part No. 11461 (Emerg)

Part No. 11462 (Service)



37° BRACKET MOUNT FILTERED ALUMINUM GLADHAND

Pipe plug in one 3/8" port.

Service:

Part No. 1011440

Emergency:

Part No. 1011441

3/8"-18 NPTF



3/8"-18 NPTF plugged.

Angle Surface-Mount Qwik-E®

Interchangeable with any angle gladhand. 3/8" ports.

Part No. 12-236



Angle Surface-Mount 38°

Interchangeable with any angle gladhand. 3/8" ports.

Part No. 12-136 (Service)

Part No. 12-138 (Emerg)

GLADHANDS - SHUT-OFF

SHUT-OFF GLADHANDS

Impregnated aluminum body.

Includes 1"-14 mounting stud with

1/2" nylon tubing compression fitting.

Emergency gladhand has

1/4" NPTF port for pintle hook.

Service: Part No. 1010120

Emergency: Part No. 1010121

(For 3/8" nylon tubing)

Service:

Part No. 36153

Emergency:

Part No. 36253



SHUT-OFF GLADHANDS

Aluminum gladhands, 3/8" NPTF port.

Emergency gladhand has 1/4" NPTF port for pintle hook.

Brass shut-off valve.

Service: Part No. 441004

Emerg: Part No. 441014

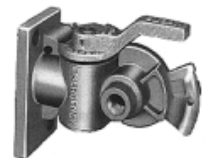

GLADHANDS - SWING AWAY AND QWIK-E®

SWING-AWAY GLADHANDS

Low projection profile from trailer skin. Stainless steel torsion spring. 45° swivel designed elbow permits optional air line entry from either bottom or back port. Gladhand cover prevents air system contamination. 3/8" bottom and back ports Includes polyurethane seal.



Service:

Part No. 441102

Emerg:

Part No. 441103

SWING-AWAY GLADHANDS (Cast Iron)

- Shut-off valve prevents contaminants from entering the system.
- Eliminates the need for a dummy coupler.
- Decreases plumbing hardware and speeds installation time.

Service: Part No. 441169

Emerg: Part No. 441170



Qwik-E® Pressure-Relieving Gladhand

The first quick release valve and gladhand in one. Replaces the service gladhand at the nose of the trailer. 1/2" NPTF.

Part No. 12-206



PHILIPS



GLADHAND LOCK AND GRIPS

GLADHAND LOCK

Hardened Plastic Body
available with various key numbers:
(141, 147, 150, 156, 157)

10 per Box

Part No. 1011455-key number



GladHand Grips

Machined steel core saves
broken air lines at the gladhand.
Part number represents
one color-coded pair.

Gladhands not included.

Part No. 1010033



GladHand Grips

Provides strong leverage for
coupling/uncoupling gladhands.

One -piece body for easy
installation. Durable and
strong; made from solid T6
aircraft aluminum.

Corrosion-resistant
anodized color coating.
Installs between aircoil
and gladhand

Part No. 12-600



GLADHAND SEALS

GLADHAND SEALS

Neoprene, black, full face.

Part No. 1010028

Neoprene, black,
Compression type.

Part No. 1010029



GLADHAND SEALS

Polyurethane

For extended service

Color

Red (Emerg.)

Blue (Service)

Black

Part No.

1010031

1010030

1010032

PROTECT-O SEAL

Helps prevent
contamination of
air system

Part No. 10024



GLADHAND FILTER

Air system protection

Part No. 1010035



GLADHAND POGO STICKS AND MORE

40" POGO STICK

Zinc plated with
yellow dichromate.
Swivels at base.
7/16"-20 stud.

Part No. 1013418



40" POGO STICK

Yellow Dichromate
with Straps & Holders

Part No. 1013543

Same as above, in chrome.

Part No. 1013544

HOSE HOLDER

For three hoses

Part No. 17-157



Qwik Snap™ HOLDER

For three hoses

Part No. 17-153



HOSE SUPPORT SPRINGS

High tensile spring steel

| Part No. | Length |
|----------|---------|
| 12.38" | 11601 |
| 15.42" | 11603 |
| 25.09" | 1013423 |
| 12.62" | 1013425 |

SUPPORT CLAMPS

For 3/8" I. D. Hose

Impact plastic.

Can be used for coiled
nylon or rubber hose.

Complete with U-bolt

Part No.1011544

Part No.1011543

20" spring.

Includes 3-hose
holder,clip, sleeve.

Part No. 17-148

Snap on clip

Part No. 17-160

Tracker Bar Kit ----->

48" bar and 20" spring.

Includes: 3-hose holder,clip, sleeve.

Part No. 17-149



GLADHAND BRACKETS

For use on pogo

Part No. 1011403

Part No. 1011402

"Dummy" Holder
w/chain

HOSE CLAMPS

3 hole hose clamp
For 3/8" and 1/2"

I.D. hoses.

Part No. 11546

2 hole, single eyebolt

clamp, for 3/8" hose

Part No. 1011541



DUMMY GLADHAND

Universal gladhand with
reinforced cable attached to
aluminum handle. Used on
rear of pups. Seals air
system from foreign matter.

Part No. 11400



HOSE SEPARATOR

Keep hoses from rubbing
together. Plastic composite

Hose Size Part No.

3/8" I. D. **1010403**

1/2" I. D. **1010404**

GLADHAND ELBOW-

Aluminum Mounting holes
2.16" on centers, 3/8" ports.

Part No. 11312

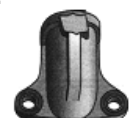

Gladhand Pacifier - Part No. 441721

- Keeps airlines and exposed gladhands free from dirt, insects and moisture.
- 2-piece nylon strap keeps pacifier handy when the airline system is connected or disconnected.
- Can be used on any gladhands.

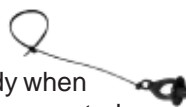



NYLON TUBING

Type A Nylon Tubing

Heat and light stabilized single wall extruded type 11 nylon tubing available in sizes 1/8", 1/4" and 5/16". This tubing conforms to SAE specification J844 Type A. The A refers to non-reinforced tubing.

PFT Type B Nylon Tubing

Heat and light stabilized seamless extruded nylon 11 core reinforced with one open ply of fibrous reinforcement and a protective nylon 11 cover sheath. The outer cover and core are fused to minimize leakage and maximize impact resistance. This tubing conforms to SAE J844 Type B. The B refers to reinforced tubing. Maximum working pressure 150 PSI.

| Tube O. D. | Part No. | Min. Bend Radius |
|------------|----------------|------------------|
| 1/8" | 1610002 | 3/8" |
| 1/4" | 1610004 | 1" |
| 5/16" | 1610005 | 1 1/4" |

| Tube O. D. | Part No. | Minimum Bend Radius |
|------------|---------------------|---------------------|
| 3/8" | 1610006 | 1 1/2" |
| 3/8" | 1610006-BLUE | 1 1/2" |
| 3/8" | 1610006-RED | 1 1/2" |
| 1/2" | 1610008 | 2" |
| 1/2" | 1610008-BLUE | 2" |
| 1/2" | 1610008-RED | 2" |
| 5/8" | 1610010 | 2 1/2" |
| 3/4" | 1610012 | 3" |



Tubing available in green, red, blue, orange, yellow, and black.



| I. D. | Part No. | I. D. | Part No. |
|-------|----------------|-------|----------------|
| 1/4" | 1011120 | 1/2" | 1011123 |
| 5/16" | 1011121 | 5/8" | 1011124 |
| 3/8" | 1011122 | 3/4" | 1011125 |
| | | 1" | 1011126 |



Vinyl Coated Tubing Clamps

COILED AIR LINES

TRACTOR TO TRAILER COILED NYLON AIR BRAKE CONNECTIONS



| Kit Number | Individual Coil Number | Tube O.D. | Valve Tail Length | Coil Ends | | Working Length |
|-----------------------------------|------------------------|-----------|-------------------|-----------|----------|----------------|
| | | | | Valve | Gladhand | |
| 7100100 (1 Red, 1 Blue) | 7100101 RED | 1/2" | 12" | 1/2 | 1/2 | 15' |
| | 7100102 BLUE | | | | | |
| 7100110 (1 Red, 1 Blue) | 7100111 RED | 1/2" | 1-40" | 1/2 | 1/2 | 15' |
| | 7100112 BLUE | | 1-12" | | | |
| 7100120 (1 Red, 1 Blue) | 7100121 RED | 1/2" | 6" | 1/2 | 1/2 | 12' |
| | 7100122 BLUE | | | | | |

- Working Pressure to 150 PSI ■ Conforms to SAE J844
- No pogo sticks or spring hangers required. ■ Temperature range: -40° F to +200° F.

■ Extra-long brass nut adds cold weather connecting leverage.

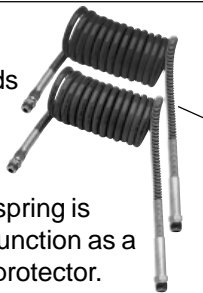

■ Extra-long spring is designed to function as a nylon tubing protector.
 ■ Vertical at the tractor end, angle-slanted at the trailer end.
 ■ 3-1/2" inch coil diameter offers greater flexibility

PHILLIPS POWER GRIP™

| Kit Number | DESCRIPTION | Tube O.D. | Valve Tail Length | Coil Ends | | Working Length |
|-----------------------------------|---|-----------|-------------------|-----------|----------|----------------|
| | | | | Valve | Gladhand | |
| 11-3400 (1 Red, 1 Blue) | 15' Pair with | 1/2" | 40" | 1/2 | 1/2 | 15' |
| | 40" coil guard (Red Only Part No. 11-3380 / Blue Only Part No. 11-3390) | | | | | |
| 11-3150 (1 Red, 1 Blue) | 15' Pair | 1/2" | 40" | 1/2 | 1/2 | 15' |
| | (Red Only Part No. 11-3170 / Blue Only Part No. 11-3180) | | | | | |

PHILLIPS POLAR AIR® (For Extreme Conditions)

| Kit Number | DESCRIPTION | Tube O.D. | Valve Tail Length | Coil Ends | | Working Length |
|-----------------------------------|---|-----------|-------------------|-----------|----------|----------------|
| | | | | Valve | Gladhand | |
| 11-5400 (1 Red, 1 Blue) | 15' Pair with | 1/2" | 40" | 1/2 | 1/2 | 15' |
| | 40" lead (Red Only Part No. 11-5401 / Blue Only Part No. 11-5402) | | | | | |

PHILATRON STALLION®



| Kit Number | Tube DESCRIPTION | Valve Tail O.D. | Coil Ends | | Working Length | |
|---------------------|----------------------|-----------------|-----------|----------------|----------------|-----|
| | | | Length | Valve Gladhand | | |
| S1-400-15CBR | 15' Red & Blue Coils | 1/2" | 10" | 1/2 | 1/2 | 15' |
| S3-600-15CBR | 15' Red & Blue Coils | 1/2" | 10" | 1/2 | 1/2 | 15' |

- Extra Heavy Duty Service ■ Meets DOT FMVSS 106 Regulations ■ Temperature range: -70° F to +200° F.
- S1-400 air lines are "standard" and have a 1 year warranty. S3-600 air lines are "Stallion Flex" and have a 3 year warranty.



AIR TANKS



***Note:** On tanks with more than one main port, port locations are 180 degrees from each other unless noted otherwise.

Tanks listed by Diameter Size.

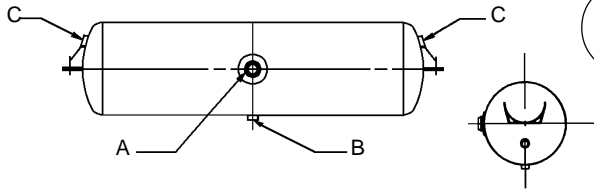

1 Main Port*

8 Inch Diameter, 1425 Cubic Inch Capacity
Mounting Holes 32 Inches Center to Center

| Part No. | (A) Main Port* | (B) Drain Port (1) | (C) End Ports (2) |
|----------------|----------------|--------------------|-------------------|
| 1010328 | 3/4" NPTF (*1) | 1/4" NPTF | 3/8" NPTF |

Reference No. HT-8001

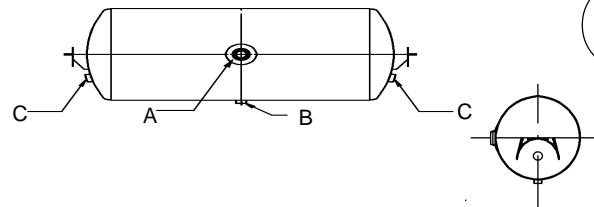

2 Main Ports*

8 Inch Diameter, 1425 Cubic Inch Capacity
Mounting Holes 32 Inches Center to Center

| Part No. | (A) Main Port* | (B) Drain Port (1) | (C) End Ports (2) |
|----------------|----------------|--------------------|-------------------|
| 1010334 | 3/4" NPTF (*2) | 1/4" NPTF | 3/8" NPTF |

Reference No. HT-8052

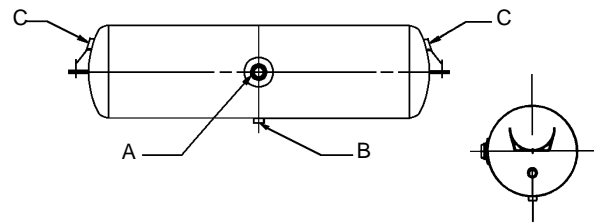

2 Main Ports*

8 Inch Diameter, 1425 Cubic Inch Capacity
Mounting Holes 32 Inches Center to Center

| Part No. | (A) Main Port (2) | (B) Drain Port (1) | (C) End Ports (2) |
|----------------|-------------------|--------------------|-------------------|
| 1010340 | 3/4" NPTF | 1/4" NPTF | 3/8" NPTF |

Reference No. HT-8007

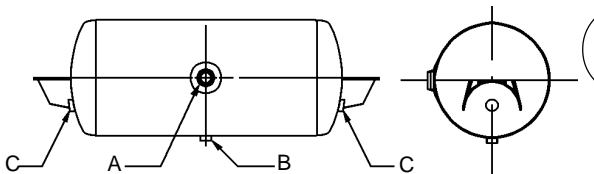

2 Main Ports*

9.5 Inch Diameter, 1488 Cubic Inch Capacity
Mounting Holes 27.5 Inches Center to Center.

| Part No. | (A) Main Port (2) | (B) Drain Port (1) | (C) End Ports (2) |
|-----------------|-------------------|--------------------|-------------------|
| N9508-AA | 3/4" NPTF | 1/4" NPTF | 3/8" NPTF |

Reference No. HT-9508

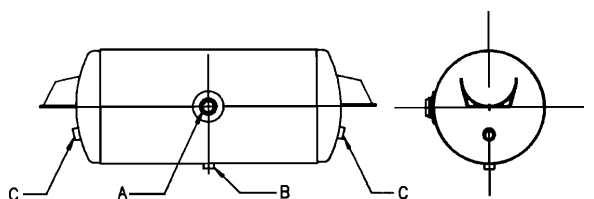

2 Main Ports*

9.5 Inch Diameter, 1488 Cubic Inch Capacity
Mounting Holes 27.5 Inches Center to Center.

| Part No. | (A) Main Port (2) | (B) Drain Port (1) | (C) End Ports (2) |
|----------------|-------------------|--------------------|-------------------|
| 1010336 | 3/4" NPTF | 1/4" NPTF | 3/8" NPTF |

Reference No. HT-9534



AIR TANKS

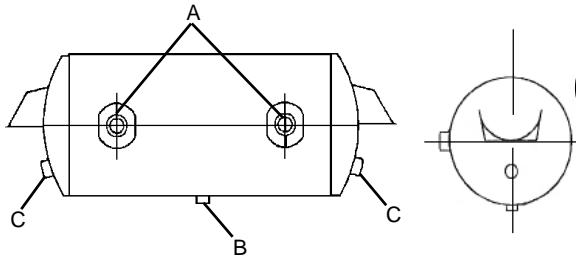

2 Main Ports*

9.5 Inch Diameter, 1488 Cubic Inch Capacity
Mounting Holes 27.5 Inches Center to Center.

| Part No. | (A) Main Port (2) | (B) Drain Port (1) | (C) End Ports (2) |
|----------|----------------------|-----------------------|----------------------|
| 1010337 | 3/4" NPTF | 1/4" NPTF | 1/2" NPTF |

Reference No. HT-9507

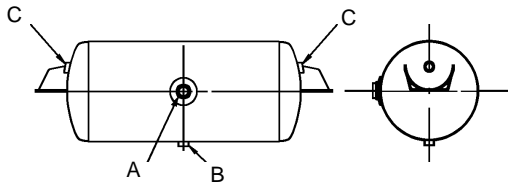

2 Main Ports*

9.5 Inch Diameter, 1488 Cubic Inch Capacity
Mounting Holes 27.5 Inches Center to Center.

| Part No. | (A) Main Port (2) | (B) Drain Port (1) | (C) End Ports (2) |
|----------|----------------------|-----------------------|----------------------|
| 1010341 | 1/2" NPTF | 1/4" NPTF | 1/2" NPTF |

Reference No. HT-9531

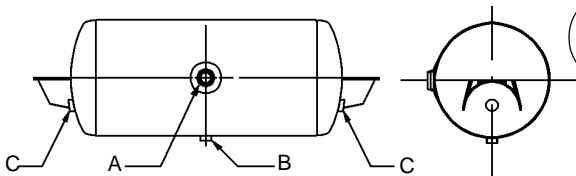

1 Main Port*

9.5 Inch Diameter, 1488 Cubic Inch Capacity
Mounting Holes 27.5 Inches Center to Center.

| Part No. | (A) Main Port (2) | (B) Drain Port (1) | (C) End Ports (2) |
|----------|----------------------------|-----------------------|----------------------|
| 1010343 | HYDRAULIC RESERVOIR | | |
| 1010344 | 3/4" NPTF | 1/4" NPTF | 3/8" NPTF |

Reference No. HT-95102

Reference No. HT-9500

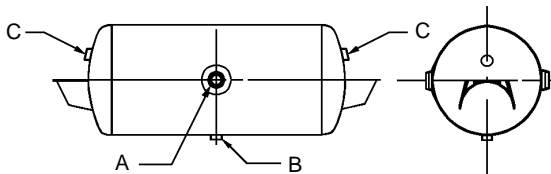

2 Main Ports*

9.5 Inch Diameter, 1488 Cubic Inch Capacity
Mounting Holes 27.5 Inches Center to Center.

| Part No. | (A) Main Port (2) | (B) Drain Port (1) | (C) End Ports (2) |
|----------|----------------------|-----------------------|----------------------|
| 1010330 | 1/2" NPTF | 1/4" NPTF | 3/8" NPTF |
| 1010342 | 1/2" NPTF | 1/4" NPTF | 1/2" NPTF |

Reference No. HT-9575

Reference No. HT-9506

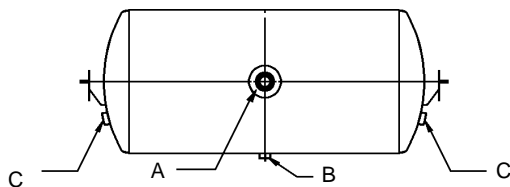

2 Main Ports*

12 Inch Diameter, 2850 Cubic Inch Capacity
Mounting Holes 29.5 Inches Center to Center.

| Part No. | (A) Main Port (2) | (B) Drain Port (1) | (C) End Ports (2) |
|----------|----------------------|-----------------------|----------------------|
| 1010329 | 3/4" NPTF | 1/4" NPTF | 3/8" NPTF |

Reference No. HT-1205

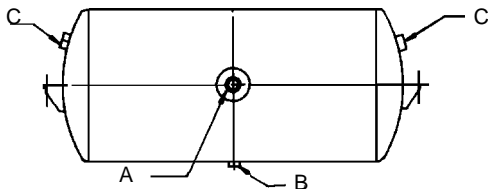

2 Main Ports*

12 Inch Diameter, 2850 Cubic Inch Capacity
Mounting Holes 29.5 Inches Center to Center.

| Part No. | (A) Main Port (2) | (B) Drain Port (1) | (C) End Ports (2) |
|----------|----------------------|-----------------------|----------------------|
| 1010331 | 1/2" NPTF | 1/4" NPTF | 3/8" NPTF |

Reference No. HT-1273



AIR TANKS

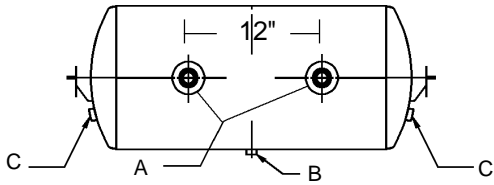

| | | | |
|------------------------------|---|-----------------------|----------------------|
| 3 Main Ports* | 12 Inch Diameter, 2850 Cubic Inch Capacity Mounting Holes 29.5 Inches Center to Center. | | |
| | (A) | (B) | (C) |
| Part No. | Main Port (3) | Drain Port (1) | End Ports (2) |
| 1010332 | 3/4" NPTF | 1/4" NPTF | 3/8" NPTF |

Reference No. HT-1219

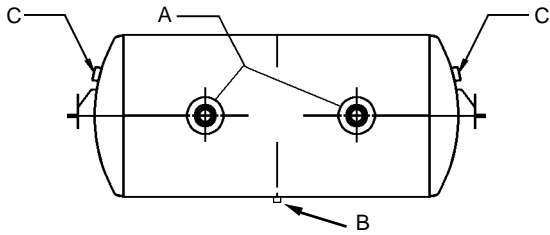

| | | | |
|------------------------------|---|-----------------------|----------------------|
| 2 Main Ports* | 12 Inch Diameter, 2850 Cubic Inch Capacity Mounting Holes 29.5 Inches Center to Center. | | |
| | (A) | (B) | (C) |
| Part No. | Main Port (2) | Drain Port (1) | End Ports (2) |
| 1010335 | 3/4" NPTF | 1/4" NPTF | 3/8" NPTF |

Reference No. HT-1217

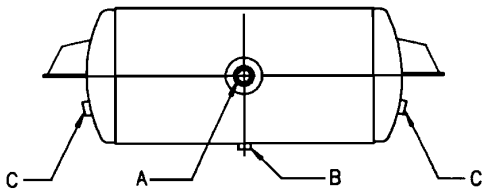

| | | | |
|------------------------------|---|-----------------------|----------------------|
| 1 Main Ports* | 12 Inch Diameter, 2850 Cubic Inch Capacity Mounting Holes 29.5 Inches Center to Center. | | |
| | (A) | (B) | (C) |
| Part No. | Main Port (1) | Drain Port (1) | End Ports (2) |
| 1010338 | 3/4" NPTF | 1/4" NPTF | 3/8" NPTF |

Reference No. HT-1211

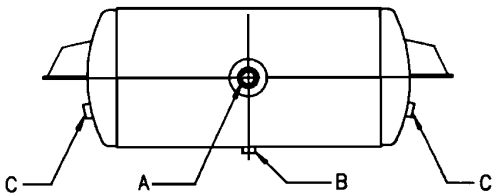

| | | | |
|------------------------------|---|-----------------------|----------------------|
| 2 Main Ports* | 12 Inch Diameter, 2850 Cubic Inch Capacity Mounting Holes 29.5 Inches Center to Center. | | |
| | (A) | (B) | (C) |
| Part No. | Main Port (2) | Drain Port (1) | End Ports (2) |
| 1010339 | 3/4" Front, 1/2" Back | 1/4" NPTF | 3/8" NPTF |

Reference No. HT-12100

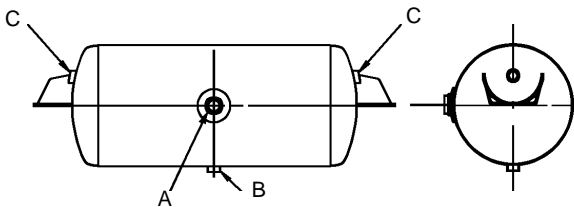

| | | | |
|------------------------------|---|-----------------------|----------------------|
| 2 Main Ports* | 13 Inch Diameter, 3000 Cubic Inch Capacity Mounting Holes 27.5 Inches Center to Center. | | |
| | (A) | (B) | (C) |
| Part No. | Main Port (2) | Drain Port (1) | End Ports (2) |
| 1010333 | 3/4" NPTF | 1/4" NPTF | 1/2" NPTF |

Reference No. HT-1301

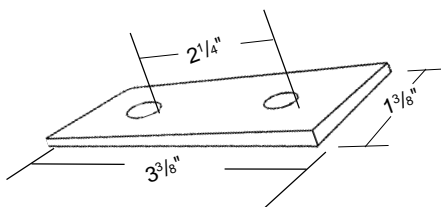

MOUNTING PAD FOR AIR TANKS

3/16" THICK RUBBER

1 1/8" wide, 3 3/8" long, 3/8" holes on 2 1/4" centers.

Two required per tank.

Part No. HT-1068



AIR TANKS

9.5 Inch Diameter, 1488 Cubic Inch Capacity

Mounting Holes 27.5 Inches Center to Center.

| Part No. | (A) Main Port | (B) Main Port | (C) Main Port | (D) Main Port | (E) Drain Port | (F) End Ports | Reference Number |
|----------|------------------|------------------|------------------|------------------|-------------------|------------------|---------------------|
| 1010351 | --- | 3/4" NPTF | --- | --- | 1/4" NPTF | 3/8" NPTF | HT-9510 |
| 1010346 | --- | 3/4" NPTF | --- | 3/4" NPTF | 1/4" NPTF | 1/2" NPTF | HT-9547 |
| 1010350 | 3/4" NPTF | --- | 3/4" NPTF | 3/4" NPTF | 1/4" NPTF | 3/8" NPTF | HT-95162 |

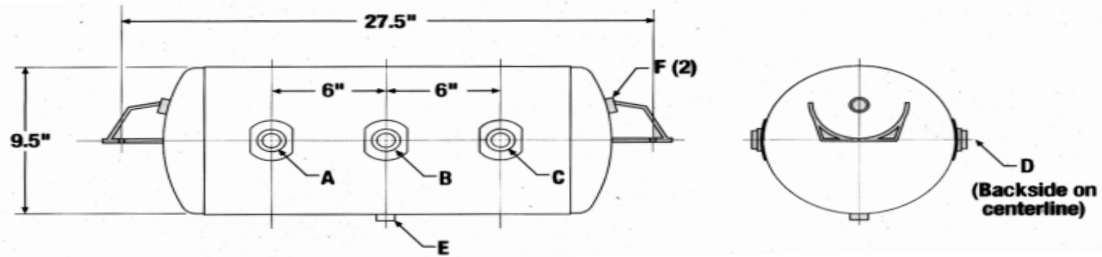

8 Inch Diameter, 1425 Cubic Inch Capacity

Mounting Holes 32 Inches Center to Center.

| Part No. | (A) Main Port | (B) Main Port | (C) Main Port | (D) Main Port | (E) Drain Port | (F) End Ports | Reference Number |
|----------|------------------|------------------|------------------|------------------|-------------------|------------------|---------------------|
| 1010347 | 3/4" NPTF | --- | 3/4" NPTF | --- | 1/4" NPTF | 3/8" NPTF | HT-8022 |
| 1010348 | 3/4" NPTF | --- | 3/4" NPTF | 3/4" NPTF | 1/4" NPTF | 3/8" NPTF | HT-8037 |

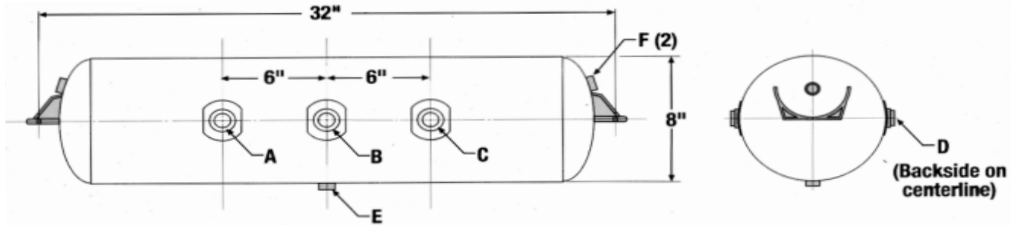

12 Inch Diameter, 2850 Cubic Inch Capacity

Mounting Holes 29.5 Inches Center to Center.

| Part No. | (A) Main Port | (B) Main Port | (C) Main Port | (D) Main Port | (E) Drain Port | (F) End Ports | Reference Number |
|----------|------------------|------------------|------------------|------------------|-------------------|------------------|---------------------|
| 1010345 | --- | 3/4" NPTF | --- | 3/4" NPTF | 1/4" NPTF | 3/8" NPTF | HT-1235 |

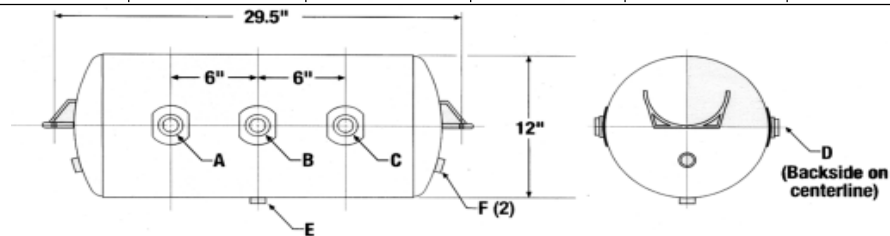

12 Inch Diameter, 2850 Cubic Inch Capacity

Mounting Holes 29.5 Inches Center to Center.

| Part No. | (A) Main Port | (B) Main Port | (C) Main Port | (D) Main Port | (E) Drain Port | (F) End Ports | Reference Number |
|----------|------------------|------------------|------------------|------------------|-------------------|------------------|---------------------|
| 1010352 | 3/4" NPTF | --- | 3/4" NPTF | 3/4" NPTF | 1/4" NPTF | 3/8" NPTF | HT-1254 |

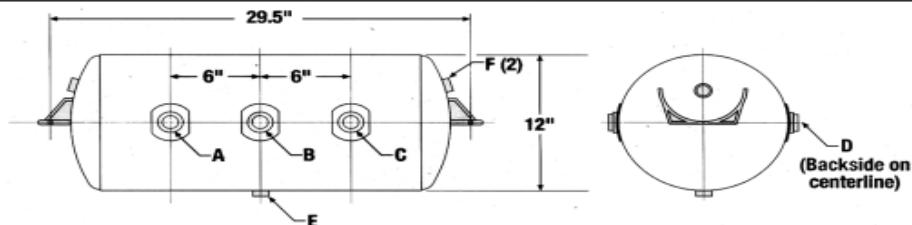



DRAIN COCKS, FLARED FITTINGS, PUSH-IN FITTINGS

SHUT OFF VALVE

Ball type valve with
1/2" NPTF both ends.
Working pressure 150 PSI.

Part No. 12116



EXTERNAL SEAT DRAIN COCK

| NPTF | Part No. |
|------|----------|
| 1/8" | DC604-2 |
| 1/4" | DC604-4 |
| 3/8" | DC604-6 |
| 1/2" | DC604-8 |



DRAIN VALVES WITH CABLE

Use on wet or dry tanks.
1/4" NPTF. Brass body
with stainless spring.

Nylon coated stainless cable.

4' Cable

Part No. FC12104

5' Cable

Part No. FC12105



DRAIN VALVES WITH CABLE

Use on wet or dry tanks.
1/4" NPTF.

Nylon coated stainless cable.

3' Cable: Part No. 12103

4' Cable: Part No. 12104

5' Cable: Part No. 12105



DRAIN COCK Part No. DCR601-4

1/4" NPTF



| DRAIN COCK | |
|------------|----------|
| NPTF | Part No. |
| 1/4" | DC601-4 |
| 3/8" | DC601-6 |
| 1/2" | DC601-8 |

| DRAIN COCK | |
|------------|----------|
| NPTF | Part No. |
| 1/8" | DC603-2 |
| 1/4" | DC603-4 |
| 3/8" | DC603-6 |

SAE 45° FLARED FITTINGS
To Be Used With Copper, Brass,
Aluminum and welded steel
hydraulic tubing that can be flared

SAE 45° FLARED FITTINGS UNION

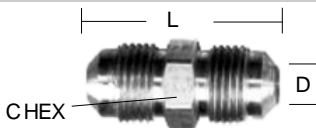

| Part No. | Tube Size | Straight Thread | C Hex | L | Flow Dia. D |
|----------|-----------|-----------------|--------|------|-------------|
| 42F-3 | 3/16 | 3/8-24 | 3/8 | 1.04 | .125 |
| 42F-4 | 1/4 | 7/16-20 | 7/16 | 1.17 | .188 |
| 42F-5 | 5/16 | 1/2-20 | 1/2 | 1.32 | .219 |
| 42F-6 | 3/8 | 5/8-18 | 5/8 | 1.48 | .281 |
| 42F-8 | 1/2 | 3/4-16 | 3/4 | 1.79 | .408 |
| 42F-10 | 5/8 | 7/8-14 | 7/8 | 2.10 | .502 |
| 42F-12 | 3/4 | 1-1/16-14 | 1-1/16 | 2.42 | .626 |

SAE 45° FLARED FITTINGS MALE CONNECTOR

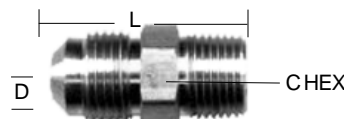

| Part No. | Tube Size | Pipe Thread | Straight Thread | C Hex | L | Flow Dia. D |
|----------|-----------|-------------|-----------------|-------|------|-------------|
| 48F-4-2 | 1/4 | 1/8 | 7/16-20 | 7/16 | 1.04 | .189 |
| 48F-4-4 | 1/4 | 1/4 | 7/16-20 | 9/16 | 1.23 | .189 |
| 48F-4-6 | 1/4 | 3/8 | 7/16-20 | 11/16 | 1.29 | .189 |
| 48F-4-8 | 1/4 | 1/2 | 7/16-20 | 7/8 | 1.54 | .189 |
| 48F-5-2 | 5/16 | 1/8 | 1/2-20 | 1/2 | 1.14 | .220 |
| 48F-5-4 | 5/16 | 1/4 | 1/2-20 | 9/16 | 1.32 | .220 |
| 48F-5-6 | 5/16 | 3/8 | 1/2-20 | 11/16 | 1.36 | .220 |
| 48F-6-2 | 3/8 | 1/8 | 5/8-18 | 5/8 | 1.23 | .220 |
| 48F-6-4 | 3/8 | 1/4 | 5/8-18 | 5/8 | 1.42 | .282 |
| 48F-6-6 | 3/8 | 3/8 | 5/8-18 | 11/16 | 1.42 | .282 |

SAE 45° FLARED FITTINGS MALE CONNECTOR

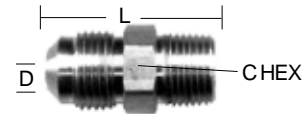

| Part No. | Tube Size | Pipe Thread | Straight Thread | C Hex | L | Flow Dia. D |
|-----------|-----------|-------------|-----------------|--------|------|-------------|
| 48F-6-8 | 3/8 | 1/2 | 5/8-18 | 7/8 | 1.67 | .282 |
| 48F-6-12 | 3/8 | 3/4 | 5/8-18 | 1-1/16 | 1.79 | .282 |
| 48F-8-4 | 1/2 | 1/4 | 3/4-16 | 3/4 | 1.60 | .408 |
| 48F-8-6 | 1/2 | 3/8 | 3/4-16 | 3/4 | 1.60 | .408 |
| 48F-8-8 | 1/2 | 1/2 | 3/4-16 | 7/8 | 1.79 | .408 |
| 48F-8-12 | 1/2 | 3/4 | 3/4-16 | 1-1/16 | 1.92 | .408 |
| 48F-10-4 | 5/8 | 1/4 | 7/8-14 | 7/8 | 1.79 | .313 |
| 48F-10-6 | 5/8 | 3/8 | 7/8-14 | 7/8 | 1.79 | .408 |
| 48F-10-8 | 5/8 | 1/2 | 7/8-14 | 7/8 | 1.98 | .501 |
| 48F-10-12 | 5/8 | 3/4 | 7/8-14 | 1-1/16 | 2.04 | .501 |
| 48F-12-8* | 3/4 | 1/2 | 1-1/16-14 | 1-1/16 | 2.17 | .562 |
| 48F-12-12 | 3/4 | 3/4 | 1-1/16-14 | 1-1/16 | 2.17 | .626 |

D.O.T. APPROVED "PUSH-IN" FITTINGS

SWIVEL 90° MALE ELBOW

| Part No. | Tube Size | Pipe Size Thread | Std. Pk. |
|--------------|-----------|------------------|----------|
| PL169PMT-4-2 | 1/4" | 1/8" | 1 |
| PL169PMT-4-4 | 1/4" | 1/4" | 1 |
| PL169PMT-6-4 | 3/8" | 1/4" | 1 |
| PL169PMT-6-6 | 3/8" | 3/8" | 1 |
| PL169PMT-6-8 | 3/8" | 1/2" | 1 |
| PL169PMT-8-6 | 1/2" | 3/8" | 1 |
| PL169PMT-8-8 | 1/2" | 1/2" | 1 |



MALE CONNECTOR

| Part No. | Tube Size | Pipe Size Thread | Std. Pk. |
|-------------|-----------|------------------|----------|
| PL68PMT-4-2 | 1/4" | 1/8" | 1 |
| PL68PMT-4-4 | 1/4" | 1/4" | 1 |
| PL68PMT-6-4 | 3/8" | 1/4" | 1 |
| PL68PMT-6-6 | 3/8" | 3/8" | 1 |
| PL68PMT-8-6 | 1/2" | 3/8" | 1 |
| PL68PMT-8-8 | 1/2" | 1/2" | 1 |



UNION

| Part No. | Tube Size | Straight Thread | B HEX | C HEX | L | M | FLOW DIA. D |
|------------|-----------|-----------------|-------|-------|------|------|-------------|
| PL62PMT-4 | 1/4 | 7/16-24 | 9/16 | 7/16 | 1.49 | .83 | .137 |
| PL62PMT-6 | 3/8 | 17/32-24 | 5/8 | 9/16 | 2.00 | 1.08 | .217 |
| PL62PMT-8 | 1/2 | 11/16-20 | 13/16 | 11/16 | 2.33 | 1.29 | .338 |
| PL62PMT-10 | 5/8 | 13/16-18 | 15/16 | 13/16 | 2.39 | 1.41 | .398 |
| PL62PMT-12 | 3/4 | 1-18 | 1-1/8 | 1 | 2.60 | 1.58 | .523 |



UNION TEE

| Part No. | Tube Size | Std. Pk. |
|------------|-----------|----------|
| PL164PMT-6 | 3/8" | 1 |
| PL164PMT-8 | 1/2" | 1 |



Push-In Adapter
3/8" NT to 1/4" NT
Part No. 1230109





D.O.T. BRASS FITTINGS FOR AIR BRAKE SYSTEMS

AIR BRAKE FITTINGS For use with Nylon Tubing Conforming to SAE J844 Type 3A and 3B

SLEEVE



| Part No. | Tube Size | D | A | L |
|----------|-----------|------|------|------|
| 60NTA-4 | 1/4 | .256 | .359 | .295 |
| 60NTA-6 | 3/8 | .384 | .479 | .390 |
| 60NTA-8 | 1/2 | .509 | .624 | .430 |
| 60NTA-10 | 5/8 | .634 | .746 | .490 |
| 60NTA-12 | 3/4 | .760 | .922 | .540 |

NUT

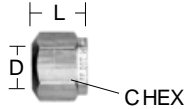

| Part No. | Tube Size | Straight Thread | C Hex | D | L |
|----------|-----------|-----------------|-------|------|-----|
| 61NTA-4 | 1/4 | 7/16-24 | 9/16 | .256 | .45 |
| 61NTA-6 | 3/8 | 17/32-24 | 5/8 | .384 | .63 |
| 61NTA-8 | 1/2 | 11/16-20 | 13/16 | .509 | .72 |
| 61NTA-10 | 5/8 | 13/16-18 | 15/16 | .634 | .77 |
| 61NTA-12 | 3/4 | 1-18 | 1-1/8 | .762 | .81 |

UNION

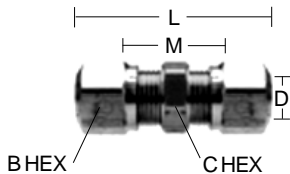

| Part No. | Tube Size | Straight Thread | B HEX | C HEX | L | M | FLOW DIA. D |
|----------|-----------|-----------------|-------|-------|------|------|-------------|
| 62NTA-4 | 1/4 | 7/16-24 | 9/16 | 7/16 | 1.49 | .83 | .137 |
| 62NTA-6 | 3/8 | 17/32-24 | 5/8 | 9/16 | 2.00 | 1.08 | .217 |
| 62NTA-8 | 1/2 | 11/16-20 | 13/16 | 11/16 | 2.33 | 1.29 | .338 |
| 62NTA-10 | 5/8 | 13/16-18 | 15/16 | 13/16 | 2.39 | 1.41 | .398 |
| 62NTA-12 | 3/4 | 1-18 | 1-1/8 | 1 | 2.60 | 1.58 | .523 |

BRASS INSERT

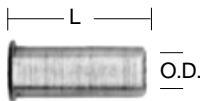

| Part No. | Tube Size | L | O.D. |
|----------|-----------|------|------|
| 63NTA-4 | 1/4 | .53 | .163 |
| 63NTA-6 | 3/8 | .64 | .245 |
| 63NTA-8 | 1/2 | .81 | .370 |
| 63NTA-10 | 5/8 | .86 | .434 |
| 63NTA-12 | 3/4 | 1.04 | .559 |

AIR BRAKE FITTINGS For use with Nylon Tubing Conforming to SAE J844 Type 3A and 3B

FEMALE CONNECTOR

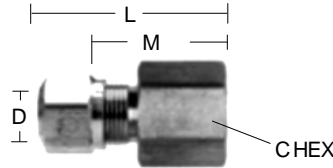

| Part No. | Tube Size | Straight Thread | Pipe Thread | L | M | N | FLOW DIA. D |
|------------|-----------|-----------------|-------------|--------|------|------|-------------|
| 66NTA-4-2 | 1/4 | 1/8 | 7/16-24 | 9/16 | 1.17 | .84 | .137 |
| 66NTA-4-4 | 1/4 | 1/4 | 7/16-24 | 11/16 | 1.40 | 1.07 | .137 |
| 66NTA-6-2 | 3/8 | 1/8 | 17/32-24 | 9/16 | 1.46 | 1.00 | .217 |
| 66NTA-6-4 | 3/8 | 1/4 | 17/32-24 | 11/16 | 1.64 | 1.18 | .217 |
| 66NTA-6-6 | 3/8 | 3/8 | 17/32-24 | 7/8 | 1.64 | 1.18 | .217 |
| 66NTA-8-6 | 1/2 | 3/8 | 11/16-20 | 7/8 | 1.79 | 1.27 | .338 |
| 66NTA-8-8 | 1/2 | 1/2 | 11/16-20 | 1-1/16 | 1.96 | 1.44 | .338 |
| 66NTA-10-6 | 5/8 | 3/8 | 13/16-18 | 7/8 | 1.80 | 1.31 | .398 |
| 66NTA-10-8 | 5/8 | 1/2 | 13/16-18 | 1-1/16 | 1.99 | 1.50 | .398 |

MALE CONNECTOR

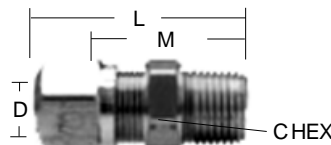

| Part No. | Tube Size | Straight Thr'd | Pipe Thr'd | C HEX | L | M | FLOW DIA. D |
|-------------|-----------|----------------|------------|--------|------|------|-------------|
| 68NTA-4-2 | 1/4 | 7/16-24 | 1/8 | 7/16 | 1.22 | .89 | 1.37 |
| 68NTA-4-4 | 1/4 | 7/16-24 | 1/4 | 9/16 | 1.43 | 1.10 | 1.37 |
| 68NTA-4-6 | 1/4 | 7/16-24 | 3/8 | 11/16 | 1.47 | 1.14 | 1.37 |
| 68NTA-6-2 | 3/8 | 17/32-24 | 1/8 | 9/16 | 1.49 | 1.03 | .217 |
| 68NTA-6-4 | 3/8 | 17/32-24 | 1/4 | 9/16 | 1.67 | 1.21 | .217 |
| 68NTA-6-6 | 3/8 | 17/32-24 | 3/8 | 11/16 | 1.70 | 1.24 | .217 |
| 68NTA-6-8 | 3/8 | 17/32-24 | 1/2 | 7/8 | 1.89 | 1.43 | .217 |
| 68NTA-8-4 | 1/2 | 11/16-20 | 1/4 | 11/16 | 1.85 | 1.33 | .338 |
| 68NTA-8-6 | 1/2 | 11/16-20 | 3/8 | 11/16 | 1.85 | 1.33 | .338 |
| 68NTA-8-8 | 1/2 | 11/16-20 | 1/2 | 7/8 | 2.04 | 1.52 | .338 |
| 68NTA-10-6 | 5/8 | 13/16-18 | 3/8 | 13/16 | 1.88 | 1.39 | .398 |
| 68NTA-10-8 | 5/8 | 13/16-18 | 1/2 | 7/8 | 2.10 | 1.58 | .398 |
| 68NTA-12-8 | 3/4 | 1-18 | 1/2 | 1 | 2.19 | 1.68 | .523 |
| 68NTA-12-12 | 3/4 | 1-18 | 3/4 | 1-1/16 | 2.22 | 1.71 | .523 |

AIR BRAKE FITTINGS For use with Nylon Tubing Conforming to SAE J844 Type 3A and 3B

UNION TEE

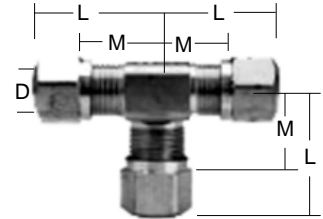

| Part No. | Tube Size | Straight Thread | L | M | FLOW DIA. D |
|-----------|-----------|-----------------|------|------|-------------|
| 264NTA-4 | 1/4 | 7/16-24 | .95 | .62 | .137 |
| 264NTA-6 | 3/8 | 17/32-24 | 1.24 | .78 | .217 |
| 264NTA-8 | 1/2 | 11/16-20 | 1.45 | .93 | .338 |
| 264NTA-10 | 5/8 | 13/16-18 | 1.58 | 1.09 | .398 |

MALE ELBOW

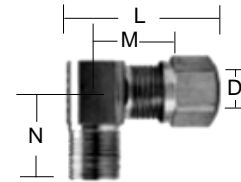

| Part No. | Tube Size | Pipe Thread | Straight Thread | L | M | N | FLOW DIA. D |
|-------------|-----------|-------------|-----------------|------|------|------|-------------|
| 269NTA-4-2 | 1/4 | 1/8 | 7/16-24 | .95 | .62 | .66 | .137 |
| 269NTA-4-4 | 1/4 | 1/4 | 7/16-24 | 1.00 | .68 | .87 | .137 |
| 269NTA-4-6 | 1/4 | 3/8 | 7/16-24 | 1.16 | .73 | .86 | .137 |
| 269NTA-6-2 | 3/8 | 1/8 | 17/32-24 | 1.19 | .73 | .75 | .217 |
| 269NTA-6-4 | 3/8 | 1/4 | 17/32-24 | 1.25 | .79 | .92 | .217 |
| 269NTA-6-6 | 3/8 | 3/8 | 17/32-24 | 1.30 | .84 | .91 | .217 |
| 269NTA-6-8 | 3/8 | 1/2 | 17/32-24 | 1.40 | .94 | 1.10 | .217 |
| 269NTA-8-4 | 1/2 | 1/4 | 11/16-20 | 1.38 | .86 | .99 | .338 |
| 269NTA-8-6 | 1/2 | 3/8 | 11/16-20 | 1.44 | .92 | .99 | .338 |
| 269NTA-8-8 | 1/2 | 1/2 | 11/16-20 | 1.55 | 1.03 | 1.18 | .338 |
| 269NTA-10-6 | 5/8 | 3/8 | 13/16-18 | 1.49 | 1.00 | 1.05 | .398 |
| 269NTA-10-8 | 5/8 | 1/2 | 13/16-18 | 1.58 | 1.09 | 1.24 | .398 |
| 269NTA-12-8 | 3/4 | 1/2 | 1-18 | 1.70 | 1.19 | 1.33 | .523 |

NOTES



D.O.T. BRASS FITTINGS FOR AIR BRAKE SYSTEMS

AIR BRAKE FITTINGS
For use with Nylon Tubing
Conforming to
SAE J844 Type 3A and 3B

MALE RUN TEE

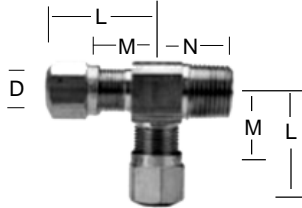

| Part No. | Tube Size | Pipe Thr'd | Straight Thread | L | M | N | Flow Dia. D |
|-------------|-----------|------------|-----------------|------|------|------|-------------|
| 271NTA-4-2 | 1/4 | 1/8 | 7/16-24 | .95 | .62 | .66 | .137 |
| 271NTA-4-4 | 1/4 | 1/4 | 7/16-24 | 1.00 | .68 | .87 | .137 |
| 271NTA-6-4 | 3/8 | 1/4 | 17/32-24 | 1.25 | .79 | .92 | .217 |
| 271NTA-6-6 | 3/8 | 3/8 | 17/32-24 | 1.30 | .84 | .91 | .217 |
| 271NTA-8-6 | 1/2 | 3/8 | 11/16-20 | 1.45 | .93 | .99 | .338 |
| 271NTA-8-8 | 1/2 | 1/2 | 11/16-20 | 1.55 | 1.03 | 1.18 | .338 |
| 271NTA-10-8 | 5/8 | 1/2 | 13/16-18 | 1.60 | 1.09 | 1.24 | .398 |

AIR BRAKE FITTINGS
For use with Nylon Tubing
Conforming to
SAE J844 Type 3A and 3B

45° ELBOW

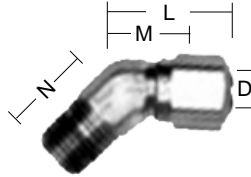

| Part No. | Tube Size | Pipe Thr'd | Straight Thread | L | M | N | Flow Dia. D |
|-------------|-----------|------------|-----------------|------|------|------|-------------|
| 279NTA-4-2 | 1/4 | 1/8 | 7/16-24 | .81 | .49 | .63 | .137 |
| 279NTA-4-4 | 1/4 | 1/4 | 7/16-24 | .93 | .60 | .85 | .137 |
| 279NTA-6-2 | 3/8 | 1/8 | 17/32-24 | 1.17 | .71 | .68 | .217 |
| 279NTA-6-4 | 3/8 | 1/4 | 17/32-24 | 1.17 | .71 | .85 | .217 |
| 279NTA-6-6 | 3/8 | 3/8 | 17/32-24 | 1.21 | .75 | .94 | .217 |
| 279NTA-6-8 | 3/8 | 1/2 | 17/32-24 | 1.24 | .78 | 1.16 | .217 |
| 279NTA-8-6 | 1/2 | 3/8 | 11/16-20 | 1.36 | .84 | .94 | .338 |
| 279NTA-8-8 | 1/2 | 1/2 | 11/16-20 | 1.39 | .87 | 1.16 | .338 |
| 279NTA-10-6 | 5/8 | 3/8 | 13/16-18 | 1.43 | .94 | .98 | .398 |
| 279NTA-10-8 | 5/8 | 1/2 | 13/16-18 | 1.42 | .93 | 1.16 | .398 |
| 279NTA-12-8 | 3/4 | 1/2 | 1-18 | 1.61 | 1.10 | 1.18 | .523 |

AIR BRAKE FITTINGS
For use with Nylon Tubing
Conforming to
SAE J844 Type 3A and 3B

MALE BRANCH TEE

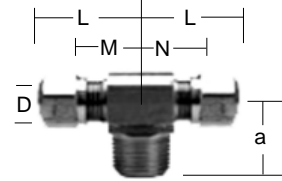

| Part No. | Tube Size | Pipe Thr'd | Straight Thread | L | M | N | Flow Dia. D |
|-------------|-----------|------------|-----------------|------|------|------|-------------|
| 272NTA-4-2 | 1/4 | 1/8 | 7/16-24 | .95 | .62 | .66 | .137 |
| 272NTA-4-4 | 1/4 | 1/4 | 7/16-24 | 1.00 | .68 | .87 | .137 |
| 272NTA-6-2 | 3/8 | 1/8 | 17/32-24 | 1.18 | .72 | .75 | .217 |
| 272NTA-6-4 | 3/8 | 1/4 | 17/32-24 | 1.25 | .91 | .92 | .217 |
| 272NTA-6-6 | 3/8 | 3/8 | 17/32-24 | 1.30 | .84 | .91 | .217 |
| 272NTA-8-4 | 1/2 | 1/4 | 11/16-20 | 1.41 | .89 | .99 | .338 |
| 272NTA-8-6 | 1/2 | 3/8 | 11/16-20 | 1.45 | .93 | .99 | .338 |
| 272NTA-8-8 | 1/2 | 1/2 | 11/16-20 | 1.55 | 1.03 | 1.18 | .338 |
| 272NTA-10-8 | 5/8 | 1/2 | 13/16-18 | 1.60 | 1.09 | 1.24 | .398 |

PIPE FITTINGS

PIPE FITTINGS
Meet Functional Requirements
of the SAE, ASME, and ASA.

COUPLING

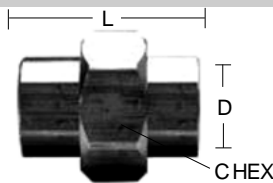

| Part No. | Pipe Thread | C Hex | L | FLOW DIA. D |
|----------|-------------|--------|------|-------------|
| 207P-2 | 1/8 | 9/16 | .75 | .328 |
| 207P-4 | 1/4 | 3/4 | 1.12 | .422 |
| 207P-6 | 3/8 | 7/8 | 1.12 | .562 |
| 207P-8 | 1/2 | 1-1/16 | 1.50 | .687 |

REDUCER COUPLING

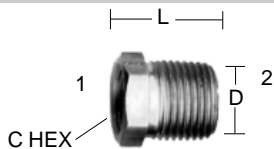

| Part No. | 1 Pipe Thread | 2 Pipe Thread | C Hex | L | FLOW DIA. D |
|----------|---------------|---------------|--------|------|-------------|
| 208P-4-2 | 1/4 | 1/8 | 3/4 | .97 | .328 |
| 208P-6-4 | 3/8 | 1/4 | 7/8 | 1.16 | .422 |
| 208P-8-4 | 1/2 | 1/4 | 1-1/16 | 1.28 | .422 |
| 208P-8-6 | 1/2 | 3/8 | 1-1/16 | 1.38 | .562 |

PIPE FITTINGS
Meet Functional Requirements
of the SAE, ASME, and ASA.

COUPLING

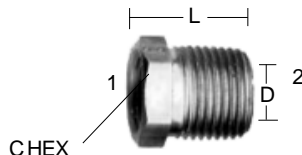

| Part No. | 1 Pipe Thread | 2 Pipe Thread | C Hex | L | FLOW DIA. D |
|-----------|---------------|---------------|-------|------|-------------|
| 209P-4-2 | 1/8 | 1/4 | 9/16 | .75 | .328 |
| 209P-6-2 | 1/8 | 3/8 | 11/16 | .75 | .328 |
| 209P-6-4 | 1/4 | 3/8 | 11/16 | .75 | .422 |
| 209P-8-2 | 1/8 | 1/2 | 7/8 | 1.00 | .328 |
| 209P-8-4 | 1/4 | 1/2 | 7/8 | 1.00 | .422 |
| 209P-8-6 | 3/8 | 1/2 | 7/8 | 1.00 | .562 |
| 209P-12-2 | 1/8 | 3/4 | 1-1/8 | 1.00 | .328 |
| 209P-12-4 | 1/4 | 3/4 | 1-1/8 | 1.00 | .422 |
| 209P-12-6 | 3/8 | 3/4 | 1-1/8 | 1.00 | .562 |
| 209P-12-8 | 1/2 | 3/4 | 1-1/8 | 1.00 | .688 |

PIPE FITTINGS
Meet Functional Requirements
of the SAE, ASME, and ASA.

SQUARE-HEAD PLUG

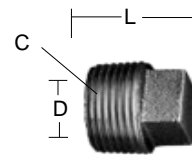

| Part No. | Pipe Thread | C Hex | L | FLOW DIA. D |
|----------|-------------|-------|------|-------------|
| 211P-2 | 1/8 | 9/32 | .59 | .25 |
| 211P-4 | 1/4 | 3/8 | .80 | .30 |
| 211P-6 | 3/8 | 15/32 | .80 | .30 |
| 211P-8 | 1/2 | 9/16 | 1.07 | .39 |
| 211P-12 | 3/4 | 5/8 | 1.14 | .45 |

CLOSE NIPPLE

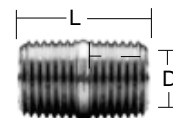

| Part No. | Pipe Thread | L Hex | FLOW DIA. D |
|----------|-------------|-------|-------------|
| 215PN-2 | 1/8 | .75 | .281 |
| 215PN-4 | 1/4 | .88 | .375 |
| 215PN-6 | 3/8 | 1.00 | .500 |
| 215PN-8 | 1/2 | 1.28 | .625 |
| 215PN-12 | 3/4 | 1.31 | .750 |



BRASS FITTINGS FOR AIR BRAKE SYSTEMS

PIPE FITTINGS
Meet Functional Requirements
of the SAE, ASME, and ASA.

LONG NIPPLE

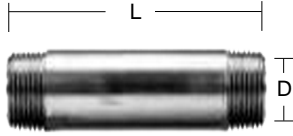

| Part No. | Pipe Thread | L Hex | FLOW DIA. D |
|-------------|-------------|-------|-------------|
| 215PNL-2-15 | 1/8 | 1-1/2 | .250 |
| 215PNL-4-15 | 1/4 | 1-1/2 | .375 |
| 215PNL-6-15 | 3/8 | 1-1/2 | .500 |
| 215PNL-8-15 | 1/2 | 1-1/2 | .625 |
| 215PNL-2-20 | 1/8 | 2 | .250 |
| 215PNL-4-20 | 1/4 | 2 | .375 |
| 215PNL-6-20 | 3/8 | 2 | .500 |
| 215PNL-8-20 | 1/2 | 2 | .625 |
| 215PNL-2-25 | 1/8 | 2-1/2 | .250 |
| 215PNL-4-25 | 1/4 | 2-1/2 | .375 |
| 215PNL-6-25 | 3/8 | 2-1/2 | .500 |
| 215PNL-8-25 | 1/2 | 2-1/2 | .625 |
| 215PNL-2-30 | 1/8 | 3 | .250 |
| 215PNL-4-30 | 1/4 | 3 | .375 |
| 215PNL-6-30 | 3/8 | 3 | .500 |
| 215PNL-8-30 | 1/2 | 3 | .680 |
| 215PNL-2-35 | 1/8 | 3-1/2 | .250 |
| 215PNL-4-35 | 1/4 | 3-1/2 | .375 |
| 215PNL-6-35 | 3/8 | 3-1/2 | .500 |
| 215PNL-8-35 | 1/2 | 3-1/2 | .680 |

HEX NIPPLE

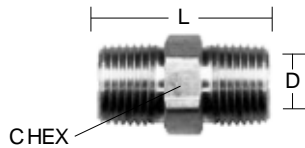

| Part No. | Pipe Thread | C Hex | L | FLOW DIA. D |
|----------|-------------|-------|------|-------------|
| 216P-2 | 1/8 | 7/16 | .97 | .220 |
| 216P-4 | 1/4 | 9/16 | 1.38 | .314 |
| 216P-6 | 3/8 | 11/16 | 1.41 | .440 |
| 216P-8 | 1/2 | 7/8 | 1.81 | .564 |

We also have **216P-6-4** reducer. 3/8 to 1/4 pipe.

HEX-HEAD PLUG

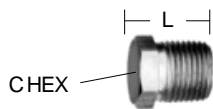

| Part No. | Pipe Thread | C Hex | L |
|----------|-------------|-------|-----|
| 218P-2 | 1/8 | 7/16 | .56 |
| 218P-4 | 1/4 | 9/16 | .75 |
| 218P-6 | 3/8 | 11/16 | .78 |
| 218P-8 | 1/2 | 7/8 | .97 |

PIPE FITTINGS
Meet Functional Requirements
of the SAE, ASME, and ASA.

COUNTERSUNK HEX PLUG

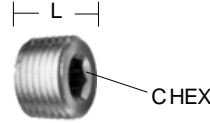

| Part No. | Pipe Thread | C Hex | L |
|----------|-------------|-------|-----|
| 219P-4 | 1/4 | 1/4 | .46 |
| 219P-6 | 3/8 | 5/16 | .47 |
| 219P-8 | 1/2 | 3/8 | .61 |

ADAPTER



| Part No. | 1 Pipe Thread | 2 Pipe Thread | C HEX | L | FLOW DIA. D |
|----------|---------------|---------------|--------|------|-------------|
| 222P-4-2 | 1/4 | 1/8 | 3/4 | 1.06 | .220 |
| 222P-4-4 | 1/4 | 1/4 | 3/4 | 1.25 | .314 |
| 222P-6-4 | 3/8 | 1/4 | 7/8 | 1.25 | .314 |
| 222P-6-6 | 3/8 | 3/8 | 7/8 | 1.25 | .440 |
| 222P-8-4 | 1/2 | 1/4 | 1 | 1.47 | .312 |
| 222P-8-6 | 1/2 | 3/8 | 1-1/16 | 1.47 | .440 |
| 222P-8-8 | 1/2 | 1/2 | 1-1/16 | 1.66 | .563 |

90° UNION ELBOW

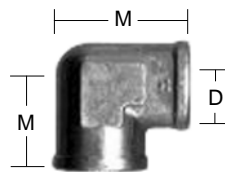

| Part No. | Pipe Thread | M | FLOW DIA. D |
|-----------|-------------|------|-------------|
| 2200P-4-4 | 1/4 | .78 | .422 |
| 2200P-6-6 | 3/8 | .84 | .563 |
| 2200P-8-8 | 1/2 | 1.09 | .687 |

90° STREET ELBOW

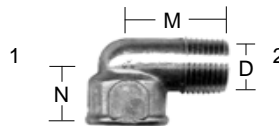

| Part No. | 1 Pipe Thread | 2 Pipe Thread | M | N | FLOW DIA. D |
|-----------|---------------|---------------|------|------|-------------|
| 2202P-2-2 | 1/8 | 1/8 | .62 | .48 | .220 |
| 2202P-4-4 | 1/4 | 1/8 | .72 | .51 | .209 |
| 2202P-6-6 | 3/8 | 3/8 | .98 | .54 | .428 |
| 2202P-8-8 | 1/2 | 1/2 | 1.25 | 1.03 | .552 |

PIPE FITTINGS
Meet Functional Requirements
of the SAE, ASME, and ASA.

UNION TEE

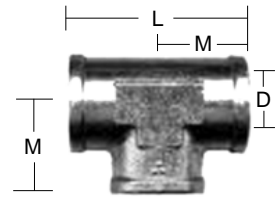

| Part No. | Pipe Thread | L | M | FLOW DIA. D |
|----------|-------------|------|------|-------------|
| 2203P-2 | 1/8 | 1.10 | .55 | .328 |
| 2203P-4 | 1/4 | 1.56 | .78 | .422 |
| 2203P-6 | 3/8 | 1.68 | .84 | .562 |
| 2203P-8 | 1/2 | 2.14 | 1.07 | .687 |

45° STREET ELBOW

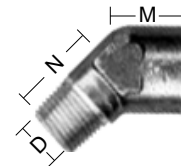

| Part No. | Pipe Thread | M | N | FLOW DIA. D |
|-----------|-------------|-----|------|-------------|
| 2214P-4-4 | 1/4 | .54 | .70 | .314 |
| 2214P-6-6 | 3/8 | .54 | .78 | .440 |
| 2214P-8-8 | 1/2 | .73 | 1.00 | .562 |

MALE BRANCH TEE

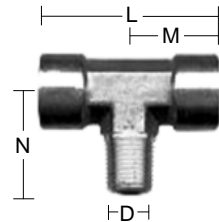

| Part No. | Pipe Thread | L | M | N | FLOW DIA. D |
|----------|-------------|------|-----|-----|-------------|
| 2224P-4 | 1/4 | 1.52 | .76 | .91 | .314 |
| 2224P-6 | 3/8 | 1.68 | .84 | .97 | .438 |

STREET TEE

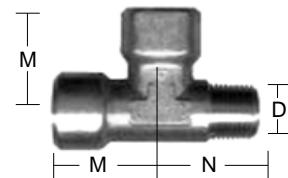

| Part No. | Pipe Thread | M | N | FLOW DIA. D |
|----------|-------------|------|------|-------------|
| 2225P-2 | 1/8 | .55 | .66 | .220 |
| 2225P-4 | 1/4 | .76 | .91 | .312 |
| 2225P-6 | 3/8 | .82 | .99 | .440 |
| 2225P-8 | 1/2 | 1.07 | 1.27 | .564 |



RADIATOR & HEATER HOSE

GOODYEAR

Standard Straight Radiator Hose - Black Cover
Heavy construction for strength to resist vibration and collapse. Cover and tube resistant to heat, ozone and all antifreeze solutions. Meets or exceeds SAE J20R1, D1 specifications.

| Standard Hose - 3 Foot Lengths | | | |
|---------------------------------|----------|---------------------------------|----------|
| Size | Part No. | Size | Part No. |
| 1" | GY56016 | 2" | GY56032 |
| 1 ¹ / ₈ " | GY56018 | 2 ¹ / ₄ " | GY56036 |
| 1 ¹ / ₄ " | GY56020 | 2 ³ / ₈ " | GY56038 |
| 1 ¹ / ₂ " | GY56024 | 2 ¹ / ₂ " | GY56040 |
| 1 ⁵ / ₈ " | GY56026 | 2 ³ / ₄ " | GY56044 |
| 1 ³ / ₄ " | GY56028 | 3" | GY56048 |
| | | 3 ¹ / ₂ " | GY56056 |



Hi-Miler® Straight Radiator Hose - Blue Cover
A long lasting high quality fleet service hose. Designed for heavy-duty service on trucks, buses and off-road equipment. Tube and cover are made with heat resistant Versigard® synthetic rubber. Reinforced with Flexten™ cord for excellent burst strength. Readily recognizable blue cover for fast identification of Hi-Miler quality. Insta-Find Number 57 designates Heavy-Duty Radiator hose in 3 foot lengths. The third digit (2) indicates that it is the Hi-Miler blue hose. The fourth and fifth digits give ID in 16th of an inch.

| Hi-Miler® Hose - 3 Foot Lengths | | | |
|---------------------------------|----------|---------------------------------|----------|
| Size | Part No. | Size | Part No. |
| 1" | GY57216 | 2 ¹ / ₄ " | GY57236 |
| 1 ¹ / ₄ " | GY57220 | 2 ³ / ₈ " | GY57238 |
| 1 ¹ / ₂ " | GY57224 | 2 ¹ / ₂ " | GY57240 |
| 1 ³ / ₄ " | GY57228 | 2 ³ / ₄ " | GY57244 |
| 2" | GY57232 | 3" | GY57248 |

GOODYEAR

HEATER HOSE

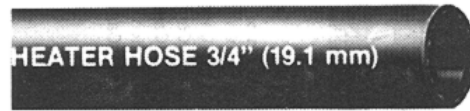

Hi-Miler® Heater Hose

Outstanding for strength and heat resistance. Made with high temperature Versigard® synthetic rubber. Reinforced with heat-resistant Flexten® cord that is pound for pound, stronger than steel. Built to out-last standard heater hose without the cost of more expensive silicone.

Recognizable blue cover.

Meets SAE J20R3, D3 specifications.

Hi-Miler® Heater Hose - 50 Foot Lengths

| I.D. | Part No. |
|------|----------|
| 3/8" | GY65028 |
| 1/2" | GY65029 |
| 5/8" | GY65031 |
| 3/4" | GY65033 |
| 1" | GY65035 |

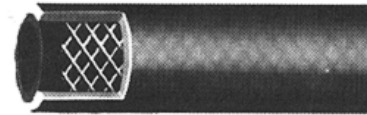

Premium HY-T Red

HY-T heater hose is made with a tough cover and tube to resist heat, ozone, and antifreeze solutions. Built to withstand the pressure and high heat buildup present under the hood of today's auto's, trucks and buses. Minimum burst pressure 140 PSI. Expands easily over heater connections, resists end tearing and splitting. Available in red cover through 3/4" I. D. Premium HY-T red heater hose meets SAE J20R3, D2 specifications.

Premium HY-T Red Heater Hose - 50 Foot Lengths

| I.D. | Part No. |
|------|----------|
| 1/2" | 1835 |
| 5/8" | 1836 |
| 3/4" | 1837 |



Standard Black Heater Hose - 50 Foot Lengths

| I.D. | Part No. |
|------|----------|
| 1/2" | 1825 |
| 5/8" | 1826 |
| 3/4" | 1827 |
| 1" | 1828 |



SERVICE HOSE

GOODYEAR



Service Hose - Service Station Air Hose

For tower, reel, and curb connections.
The synthetic rubber tube and blue cover assures long life against ozone, weathering and heat.
Maximum working pressure of 250 PSI.
Swivel fittings on each length.

| Size | Ends | Part No. |
|----------------|---------|----------|
| 3/8" x 50' w/c | 1/4 NPT | GY65137 |
| 1/2" x 50' w/c | 1/2 NPT | GY65138 |

GOODYEAR

Truck Component Hose

Hysunite® Fuel Line/Emission Control Hose

Especially for gasohol and later carbureted vehicle applications with high under the hood temperatures. Cover is oil and gasoline resistant and withstands exposure to fuel, vapor, moisture and high heat up to 250 degree F.
(Warning - For fuel injected vehicles, use SAE J30R9 fuel injection hose.)

| Size | Part No. |
|-------------|----------|
| 3/16" x 25' | GY65125 |
| 1/4" x 25' | GY65126 |
| 5/16" x 25' | GY65127 |
| 3/8" x 25' | GY65128 |

HYDRAULIC HOSE - HYDRAULIC QUICK COUPLINGS



Parker

SAE J1402 All Medium Pressure Hose

One wire braid, textile cover. For high temperature engine and brake requirements.

Use with 20 Series and 22 Series fittings.

Construction:

Synthetic rubber tube, textile inner braid, high tensile steel wire braid reinforcement, textile braid cover.

Application:

Medium pressure hydraulic, turbo charger, filtration and oil lines, diesel fuel filter, engine and transmission coolant lines, air brake, power steering and tilt cab.

SAE J1402 and D.O.T. FMVSS 106-

All air brake hose requirements.

Temperature Range:

-40 Deg. F to +300 Deg. F, 150 Deg. F maximum

| Maximum Working Pressure (PSI) | Minimum Bend Radius | Hose O.D. | Hose I.D. | Part No. |
|--------------------------------|---------------------|-----------|-----------|-----------|
| 2500 | 3.000 | .52 | 3/16 | 201-4-BX |
| 2000 | 4.000 | .67 | 5/16 | 201-6-BX |
| 2000 | 4.625 | .77 | 13/32 | 201-8-BX |
| 1750 | 6.500 | .92 | 1/2 | 201-10-BX |

6100 Series Hydraulic Quick Disconnect Couplings

Parker's 6100 Series thread to connect couplings can be used in a wide variety of industrial applications where heavy-duty couplings are required that can be connected under pressure with little or no spillage.
Temperature Range -40° F to +250° F.



Brass Nipple

| Body Size (In.) | Thread Size NPTF | With Flange Part No. | Without Flange Part No. |
|-------------------------------|---|----------------------|-------------------------|
| 1 | 1-11 ¹ / ₂ | 6115-16 | 6105-16 |
| 1 ¹ / ₄ | 1 ¹ / ₄ -11 ¹ / ₂ | | 6105-20 |



Wing Nut Coupler

| Body Size (In.) | Thread Size NPTF | Brass Part No. |
|-------------------------------|---|----------------|
| 1 | 1-11 ¹ / ₂ | 6125-16 |
| 1 ¹ / ₄ | 1 ¹ / ₄ -11 ¹ / ₂ | 6125-20 |

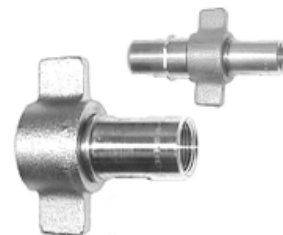

Dust Plugs and Caps

| Body Size (In.) | Dust Plug Part No. | Dust Cap Part No. |
|-----------------|--------------------|-------------------|
| 1 | 6109-16 | 6108-16 |



6600 Series Hydraulic Quick Couplings

Versatile Parker 6600 Series couplings are used in a wide range of hydraulic applications. They can be found anywhere the fluid transfer lines need to be connected and disconnected for operation or maintenance of equipment.
Temperature Range -40° F to +250° F.

Part No. 6601-16-16
Female thread coupler.
1" body. 4.11" long, 1.88" Hex.

Part No. 6602-16-16
Female thread nipple.
1" body. 3.11" long, 1.62" Hex.





HOSE CLAMPS



Power - Seal®
General Purpose Industrial Clamps
 Stainless steel band and housing with carbon steel slotted hex head screw. General purpose three-piece clamps. Interlocked construction, no welds, no bumps. Exceeds all SAE requirements. Use for all standard clamp applications.

| (Box = 10) | Effective Diameter Range | | | |
|------------|---------------------------------|------|--------------------------------|------|
| | Min. | | Max. | |
| | In. | m m. | In. | m m. |
| BR62006 | 7/16 | 11 | 25/32 | 20 |
| BR62008 | 1/2 | 13 | 29/32 | 23 |
| BR62010 | 9/16 | 14 | 1 ¹ / ₁₆ | 27 |
| BR62012 | 1 ¹ / ₁₆ | 17 | 1 ¹ / ₄ | 32 |
| BR62016 | 1 ³ / ₁₆ | 21 | 1 ¹ / ₂ | 38 |
| BR62020 | 1 ³ / ₁₆ | 21 | 1 ³ / ₄ | 44 |
| BR62024 | 1 ¹ / ₁₆ | 27 | 2 | 51 |
| BR62028 | 1 ⁵ / ₁₆ | 33 | 2 ¹ / ₄ | 57 |
| BR62032 | 1 ⁹ / ₁₆ | 40 | 2 ¹ / ₂ | 64 |
| BR62036 | 1 ¹³ / ₁₆ | 46 | 2 ³ / ₄ | 70 |
| BR62040 | 2 ¹ / ₁₆ | 52 | 3 | 76 |
| BR62044 | 2 ⁵ / ₁₆ | 59 | 3 ¹ / ₄ | 83 |
| BR62048 | 2 ⁹ / ₁₆ | 65 | 3 ¹ / ₂ | 89 |
| BR62052 | 2 ¹³ / ₁₆ | 71 | 3 ³ / ₄ | 95 |
| BR62056 | 3 ¹ / ₁₆ | 78 | 4 | 102 |
| BR62064 | 3 ⁹ / ₁₆ | 91 | 4 ¹ / ₂ | 114 |
| BR62072 | 1 ⁷ / ₈ | 48 | 5 | 127 |
| BR62080 | 2 ¹ / ₂ | 64 | 5 ¹ / ₂ | 140 |
| BR62096 | 3 ⁵ / ₈ | 92 | 6 ¹ / ₂ | 165 |
| BR62104 | 4 ¹ / ₈ | 108 | 7 | 178 |

BREEZE Constant-Torque® Clamping System

A revolutionary clamp that reacts to changes in hose systems by actually increasing or decreasing its own diameter as the system expands or contracts. Specifically recommended for coolant lines. 100% stainless steel. OEM approved.

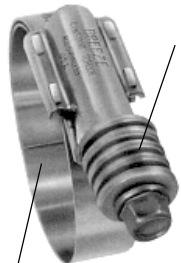

Energy stored in compressed Belleville springs controls automatic clamp adjustment

Liner protects soft or silicone hose from damage, extrusion, or shear.

| (Box = 10) | Effective Diameter Range | | | |
|---|-------------------------------|------|--------------------------------|------|
| | Min. | | Max. | |
| | In. | m m. | In. | m m. |
| Part No. | | | | |
| AERO-SEAL construction for use on small diameter applications - torque rated 30-70 in./lbs. | | | | |
| CT9410 | 13/16 | 21 | 1 ¹ / ₁₆ | 27 |
| CT9412 | 15/16 | 24 | 1 ¹ / ₄ | 32 |
| CT9416 | 13/16 | 21 | 1 ¹ / ₂ | 38 |
| Heavy-duty construction for use on large diameter applications - torque rated 50-125 in./lbs. | | | | |
| CT175L | 1 | 25 | 1 ³ / ₄ | 44 |
| CT200L | 1 ¹ / ₄ | 32 | 2 ¹ / ₈ | 54 |
| CT250L | 1 ³ / ₄ | 45 | 2 ⁵ / ₈ | 67 |
| CT300L | 2 ³ / ₄ | 57 | 3 ¹ / ₈ | 79 |
| CT350L | 2 ³ / ₄ | 70 | 3 ⁵ / ₈ | 92 |
| CT400L | 3 ¹ / ₄ | 83 | 4 ¹ / ₈ | 105 |
| CT450L | 3 ³ / ₄ | 95 | 4 ⁵ / ₈ | 118 |
| CT500L | 4 ¹ / ₄ | 108 | 5 ¹ / ₈ | 130 |

Miniature Clamps

A lightweight streamline clamp generally used in small diameter applications such as air and fuel lines. The streamline configuration allows for installation in tight fitting or difficult to reach areas. This clamp creates high sealing pressure with only 10 to 15 in./lbs. of installation torque.



| (Box = 10) | Effective Diameter Range | | | |
|------------|--------------------------|------|--------------------------------|------|
| | Min. | | Max. | |
| | In. | m m. | In. | m m. |
| Part No. | | | | |
| BR3504 | 7/32 | 5.6 | 5/8 | 16 |
| BR3506 | 7/16 | 11 | 25/32 | 20 |
| BR3508 | 1/2 | 13 | 15/16 | 24 |
| BR3510 | 9/16 | 14 | 1 ¹ / ₁₆ | 27 |

AERO-SEAL® Liner Clamps for Soft/Silicone Hose

Stainless steel band, saddle and housing with a carbon steel 5/16" hex screw. Aero-Seal Quadra-lock construction for extra strength. Integral extension of the band as a liner - no rivets or welds. Protects soft-surface hose (silicone and others) from damage caused by extrusion or shearing through the band slots. Breeze liner clamps give the truest concentric seal of any clamp made.



| (Box = 10) | Effective Diameter Range | | | |
|------------|---------------------------------|------|--------------------------------|------|
| | Min. | | Max. | |
| | In. | m m. | In. | m m. |
| Part No. | | | | |
| BR9206 | 9/16 | 14 | 13/16 | 21 |
| BR9208 | 11/16 | 17 | 15/16 | 24 |
| BR9210 | 13/16 | 21 | 1 ¹ / ₁₆ | 27 |
| BR9212 | 15/16 | 24 | 1 ¹ / ₄ | 32 |
| BR9216 | 13/16 | 21 | 1 ¹ / ₂ | 38 |
| BR9220 | 13/16 | 21 | 1 ³ / ₄ | 44 |
| BR9224 | 1 ¹ / ₁₆ | 27 | 2 | 51 |
| BR9228 | 1 ⁵ / ₁₆ | 33 | 2 ¹ / ₄ | 57 |
| BR9232 | 1 ⁹ / ₁₆ | 40 | 2 ¹ / ₂ | 64 |
| BR9236 | 1 ¹³ / ₁₆ | 46 | 2 ³ / ₄ | 70 |
| BR9240 | 2 ¹ / ₁₆ | 52 | 3 | 76 |
| BR9244 | 2 ⁵ / ₁₆ | 59 | 3 ¹ / ₄ | 83 |
| BR9248 | 2 ⁹ / ₁₆ | 65 | 3 ¹ / ₂ | 89 |
| BR9252 | 2 ¹³ / ₁₆ | 71 | 3 ³ / ₄ | 95 |

BREEZE®

BREEZE CLAMP PRODUCTS

BREEZE®



AXLE KITS - An introduction - INFORMATION

We Love to Customize Axle Kits!

Special orders - We Love Them! What do you need?
Let our Axle Pro Shop assemble the axle kit for you,
and all you have to do is install it!



Standard Trailer Axle (Typical)

- Axle Tube
- Brake shoe and lining assemblies
- Cam and chamber support brackets
- Camshafts, and camshaft busings
- 16.5x7 inch Q brakes
- Stamped brake spider
- Standard spindle nut pack

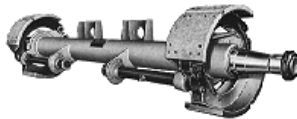

Dressed Trailer Axle (Typical)

- The same features as a standard axle plus:
- 10-stud x 11.25 BC hubs with studs for hub-piloted dual steel wheels
 - Outboard-mounted cast brake drums
 - Bearings
 - Wheel-end seals
 - Hubcaps
 - Wheel-end lubricant



Features To Consider When Ordering Axle Kits

Our Axle kits are covered by part numbers made up of codes . These codes represent various axle components. These components are loose; however axles can be ordered with components assembled by simply adding an "A" to the beginning of the part number. (Example: AS08-1309-2008-09) Because of the wide selection of axles available from stock, orders for assembled axle kits can be filled on short notice.

Look over the listings on the following pages. If you need more information, call us. **We can help!**

Type of Slack Adjusters

Per Docket No. 91-21 Notice of the Federal Register, all air-braked vehicles requiring FMVSS-121 compliance built on or after October 20, 1994 will need to be equipped with automatic slack adjusters and stroke-indicating air chambers. Axles are still available with manual slack adjusters, however these axles should only be used on 121-exempt vehicles. Ultimate responsibility for compliance lies with the vehicle manufacturer or axle installer.

ABS RULES

Because of government mandates, all trailers built after March of 1997 must be equipped with ABS. On replacement axles, care must be taken to equip the replacement axle to match existing systems.

Using this guide, we will have a part number similar to the example below, that we use to order your axle kit.
Just by us getting some quick answers to these questions:

Part No. AS54-1311-0802-51

Do you want your axle components assembled? Yes / No The example calls for an assembled axle.

Type of bearings? The example calls for Timken bearings.

Axle? In the example, the axle being used is part number 1014057. See the following pages listing axles.

Oil Seals? Choose the seal of your choice, making sure it is compatible with the axle you are using. The example is using Stemco.

Hubcaps? Make sure the hubcap you choose will work with the wheels that will be used. The example is using two six hole aluminum hub caps. Stemco 300-4009

Slack adjusters? These should be compatible with the cams on your axle. The example calls for R801074 Meritor auto slacks.

Air Chambers? The example here calls for an Anchorlok sealed GC3030 spring brake part number.

Cast Wheels or Hubs? Make sure it works with the axle being used.

The example calls for a set of ten-stud hub and drum unimount assembliesw/ABS tone ring (Webb)



ARVIN MERITOR AXLE SERIES

Arvin Meritor, one of the Premier Manufacturers of Trailer Axles, is well represented here at New Life. The Following Listing explains the types of axles and benefits.

ArvinMeritor™

TN SERIES

ArvinMeritor™

The Meritor TN Series is the industry workhorse - an economical, standard-use axle, highly suitable for a wide range of vocational applications. ArvinMeritor's pioneering and introduction of many unique features and benefits have made the TN Series the standard on more trailers than any other axle. TN capacity is 22,500 lb. - 1/2" wall thick.

Features

- Lightweight Design
- Integral spindles with induction hardening of critical areas, such as both bearing journals, and integral stamped spiders.
- Closely controlled spindle alignment.
- Available with Meritor Q or Q Plus™ "quick change" brakes.

Benefits

- Maximizes fuel efficiency and ability to carry increased payloads.
- Enhances strength and durability.
- Improves Tire Life.
- Increases service intervals

TQ SERIES

Extra heavy-duty Meritor TQ axles are designed specifically to endure the severe torsional forces exerted on an axle by air ride suspensions. When used as a standard suspension, however, the TQ axle also stands up much better against forces exerting downward pressure on the suspension. What that means is that the Meritor TQ trailer axles are appropriate when heavier-than-normal cargos will routinely be transported. TQ capacity is 25,000 lb. 5/8" wall.

Features

- Thicker axle wall than the TN Series axle.
- Standard bolt-on bushing assembly.
- Lightest weight extra heavy-duty axle in the industry

Benefits

- Provides rugged design that can withstand stress caused by torque rod action.
- Provides long-life, easy-to-service assembly that can withstand the demanding forces of heavy-duty applications.
- Maximizes fuel efficiency and ability to carry.

TP SERIES

The Meritor TP Series axle is the axle to use when you need compatibility to the Pro-Par™ type wheel end. If this type of axle is in the fleet, wheel end components are interchangeable with that design. TP capacity is 25,000 lb. 5/8" thick wall.

Features

- Inner and outer axle bearings that are the same size. Most TP axle brake parts are interchangeable with those featured on Meritor Drive axles.
- Standard Q series brakes.
- Optional Q Plus™ brakes

Benefits

- Reduces inventory requirements.
- Can be changed in two minutes or less, no tools.
- Provides longer service intervals.



ARVIN MERITOR TRAILER AXLES

ArvinMeritor has provided industry-leading systems and components to help the commercial vehicle industry safely transport goods for nearly a century.

From their inception, ArvinMeritor engineering and manufacturing leadership has moved the industry forward safely with innovative products that save fuel and money.

ArvinMeritor™

Standard Meritor production trailer axles are engineered to provide the safety and performance that today's commercial trailers require, including:

- Lightweight integral spindles that are formed from the axle tube, contributing to exceptional strength and trueness of wheel-end alignment.
- Induction-hardened bearing journals for added strength and wear resistance.
 - Stamped-steel brake spiders offer excellent strength-to-weight ratio.
- Robotically welded chamber and camshaft brackets for accurate axle alignment.

~~All of these axles are 5" round and "ABS-Ready" which means they have the ABS blocks welded on them, ready for the sensor clip and sensor.

~~They all have Q+ camshafts and 16.5 x 7 Q brake shoes except where noted.

~~Track is measured center of duals to center of duals. Or,

~~71.5" track is for 96" wide trailer and 77.5" track is for 102" wide trailer.

| <u>Part No.</u> | <u>Track</u> | <u>Rating (Lb.)</u> | <u>Cam Info</u> | <u>Bearings</u> | <u>Notes</u> |
|-----------------|--------------|---------------------|-------------------|-----------------|---------------------|
| 1014047-ABS | 77.5" | 22,500 | 20.47", 28 spline | HM combo | spring ride |
| 1014048-ABS | 71.5" | 22,500 | 17.38", 28 spline | HM combo | spring ride |
| 1014050-ABS | 77.5" | 22,500 | 17.38", 28 spline | HM combo | spring ride |
| 1014054-ABS | 71.5" | 25,000 | 24.14", 28 spline | HM combo | air ride |
| 1014055-ABS | 77.5" | 25,000 | 24.14", 28 spline | HM combo | air ride |
| 1014057-ABS | 71.5" | 22,500 | 20.47", 28 spline | HM combo | spring ride |
| 1014058-ABS | 96.0" | 25,000 | 24.14", 28 spline | HM combo | Wide Track |
| 1014061-ABS | 71.5" | 25,000 | 24.14", 28 spline | Propar | air ride, 5" round |
| 1014062-ABS | 77.5" | 25,000 | 24.14", 28 spline | Propar | air ride, 5" round |
| 1014155-ABS | 77.5" | 25,000 | 24.14", 28 spline | HM combo | Q+shoes, air ride |
| TP9671QR7350 | 77.5" | 30,000 | 24.14", 28 spline | HM combo | 3/4" wall, air ride |

T **ech** **Note:**

To maintain the specified weight capacity of a new trailer axle, it is important that the proper spring seat spacing is used. The capacities given here are based on 38" spring centers for axles with 71-1/2" track, and 44" centers for axles with 77-1/2" track. Locating the spring centers closer to the center of the axle results in lost carrying capacity for that axle.

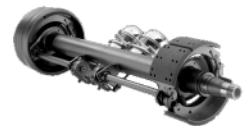



HENDRICKSON TRAILER AXLES (Formerly Dana Spicer)

Hendrickson Trailer Axle products are manufactured to the same high standards as Original Equipment (OE) parts – because they are OE parts. That means when an axle part is replaced with a genuine Spicer product, it's being replaced with the original equipment product, ensuring the same performance and reliability you've come to expect.

Hendrickson gives fleet owners and owner operators peace of mind.

They know they can rely on us for durable, high-performance, cost-effective axles in an array of configurations, tube designs, track lengths and spindle designs.

Backed by Hendrickson's outstanding technical support staff and limited warranty, Hendrickson trailer axles provide the solution to your trailer axle needs.



~~All of these axles are 5" round and "ABS-Ready" which means they have the ABS blocks welded on them, ready for the sensor clip and sensor, except where noted.

~~They all have Q+ camshafts and 16.5 x 7 Q brake shoes except where noted.

~~Track is measured center of duals to center of duals. Or,

~~71.5" track is for 96" wide trailer and 77.5" track is for 102" wide trailer.

| Part No. | Track | Rating (Lb.) | Cam Info | Bearings | Notes |
|-----------------|--------------|---------------------|-------------------|-----------------|------------------------------|
| 1011655-ABS | 71.5" | 22,500 | 23.38", 28 spline | HM combo | 12.25x7.5 shoes, spring ride |
| 1011657-ABS | 71.5" | 25,000 | 23.38", 28 spline | HM combo | 12.25x7.5 shoes, air ride |
| 1011658-ABS | 77.5" | 25,000 | 23.38", 28 spline | HM combo | 12.25x7.5 shoes, air ride |
| 10112559 | 71.5" | 22,500 | 23.75", 28 spline | 663/212049 | not abs ready |
| 2214047-ABS | 77.5" | 22,500 | 20.63", 28 spline | HM combo | spring ring |
| 2214051-ABS | 77.5" | 22,500 | 23.75", 28 spline | HM combo | spring ride |
| 2214053 | 71.5" | 22,500 | 21.38", 28 spline | HM combo | Drop Center, no abs |
| 2214054-ABS | 71.5" | 25,000 | 23.75", 28 spline | HM combo | air ride |
| 2214055-ABS | 77.5" | 25,000 | 23.75", 28 spline | HM combo | air ride |
| 2214057-ABS | 71.5" | 22,500 | 20.63", 28 spline | HM combo | spring ride |
| 2214058 | 96" | 25,000 | 23.75", 28 spline | HM combo | Wide Track, no abs. |
| 2214061-ABS | 71.5" | 25,000 | 23.75", 28 spline | Propar | 5" round, Propar |
| 2214062-ABS | 77.5" | 25,000 | 23.75", 28 spline | Propar | 5" round, Propar |
| 2214065-ABS-CE | 77.5" | 30,000 | 23.75" 28 spline | HM combo | 3/4" wall, w/cam enc. |
| 2214073 | 71.5" | 22,500 | 21.38", 28 spline | HM combo | Drop Center, no abs |



**BRAKE SPIDER**

| Part No. | Description | Replaces | |
|-----------------|--|---|---|
| E-957 | For 16-1/2" diameter brakes; | M737, 2-132, L517 |  |
| Brake | 5-5/8" diameter pilot hole, | Std. Forge 200999-010 | |
| Spider | 16 holes for 1/2" diameter bolts. | Meritor A3211A833 | |
| | Complete with nylon bushing installed. | Eaton B-1593-1 Dana/Spicer M16WS135X | |

Easy Anchor Pin Removal and Replacement.
Prevents Bending of Spiders Caused
by Driving Out Frozen Anchor Pins.
Allows Adjustment for Wear.
INCLUDES: E-1416 Seal
and E-759 Bushing

**AXLE DUST SHIELDS**

NOTE: Dust shields are easily damaged if they are installed before the axle is on the vehicle.
For this reason, they are not available as part of an axle kit, unless requested.

STEEL DUST SHIELD

One Piece Universal
Bolt-On For
16 1/2" x 7" brakes.
For applications
on Eaton,
Rockwell, Spicer.
Replaces E-886,
M1583, 02-507

**Part No. E-886****ArvinMeritor.****STEEL DUST SHIELD**

One Piece
For Axles
with fabricated
steel spiders.
Replaces
A2-3264-N-1236
As-3264-P-1238
E-9095

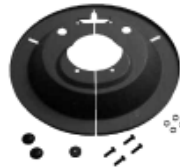
**Part No. R009095****ArvinMeritor.****STEEL DUST SHIELD**

2 Piece Bolt-On For
16 1/2" x 7" "Q" and "P"
brakes. For
applications
on Eaton,
Rockwell, Spicer.
6 holes - 7/16".
Outer diameter 18-1/8".
Inner diameter 10-11/16".
Part No. A13236Q2123

**PLASTIC DUST SHIELD**

For 5" Round Axles.
Installed on axle beam
using clamping
hardware included.
3/4" wide-1/8" thick steel
clamp (#HTM550).

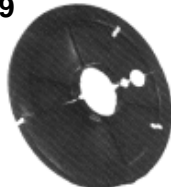
Part No. 1012019**DUST SHIELD KIT - SEALED**

From Hendrickson, this dust shield
kit works to eliminate the elements
of dirt and grime that penetrate the
brakes. Comes with clamping
hardware kit. One piece shield is
for 16.5" brakes with 5" diameter
axle. Create a sealed unit with
grommet and port plug. Installation
instructions included.

Part No. S28500-1650

Sealed Dust shield Kit
Kit Contains:

- Dust shield Clamp
- Grommet
- Blind Grommet
- Split Grommet
- Clamp-On Dust shield

