

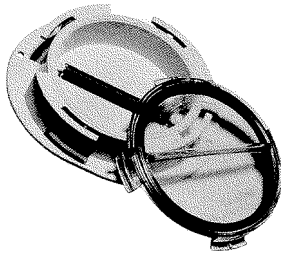

DOCUMENT HOLDERS

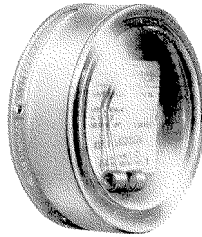

Plastic Document Holder	
Made of chemical resistant high impact plastic. Cover is smoked polycarbonate and includes permanently adhered gasket. Moisture resistant.	
Part No.	Size
TL97960	5.86" x 5.22" x 1.85"



Lexan Certificate Holder	
Surface mount, with spring retainer, tough Lexan body and lens.	
Part No.	Size
820012	4 ⁷ / ₈ " x 5 ⁷ / ₈ " x 1 ⁵ / ₈ "



Document Holder		
Rugged aluminum extruded one piece holder with 4 hole mount Railroad approved.		
Part No.	Dia.	Length
1011536	1 ⁵ / ₈ "	7"
Rubber End Plugs		
1011536-1	--	--

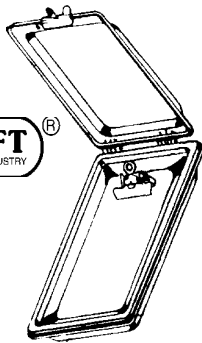

Aluminum Manifest Box	
Mill finish aluminum with stainless steel hardware. Top closes into foam gasket, keeping contents dry. Three 1/4" mounting holes.	
Part No.	Size
1011535	8 ³ / ₈ " x 13 ³ / ₈ " x 1 ¹ / ₂ "



Permit Holder	
Laminated for all weather protection. Sealing zipper for easy insertion of paper. Four mounting holes with grommets for easy mounting.	
Part No.	Size
GR43411	6" x 9"

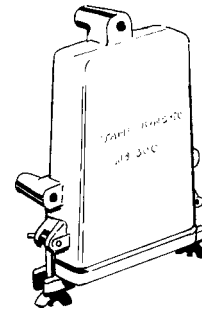

Diecast Aluminum Security Box	
Convenient waterproof storage licenses, permits, maintenance records, titles and registration papers. Clipboard size: 3 ¹ / ₂ " x 5 ¹ / ₄ " Lid available under Part No. JK300L.	
Part No.	Size
JK300	5 ¹ / ₄ " x 7" x 2"

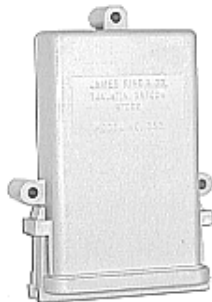

Model 350 Security Box	
Space age "Xenoy" construction. Waterproof protection for titles, licenses, vehicle inspection certificates, etc. Enclosure size: 3 ¹ / ₂ " x 5" x 1"	
Part No.	Size
JK350	5 ¹ / ₄ " x 7" x 2"



Model 500 Record Box	
Waterproof protection for all permits, manifests, logs and registrations. Heavy duty high impact plastic. Inside size: 10" x 14".	
Part No.	Size
JK500	11 ¹ / ₂ " x 16" x 2"



Model 550 Record Box	
Thin box. Will mount on side of exterior post trailer or container without exceeding width limit. Inside size 9 ¹ / ₂ " x 12 ¹ / ₄ " x 3/4". High impact plastic. Lid Part No. JK550L.	
Part No.	Size
JK550	10" x 15" x 1 ¹ / ₄ "



TRAILER BODY PARTS ACCESSORIES

Grote



Permit Holder	
Formed rust-proof housing with vinyl pouch with self sealing zipper for easy insertion of paper. Easy mounting. Frame O.D. 4 ⁷ / ₈ " x 7 ³ / ₁₆ ".	
Part No.	Window Size
1010248	3 ⁷ / ₈ " x 5 ¹ / ₈ "

Skylights are molded in one piece from shatter-proof translucent fiberglass reinforced plastic. Supplied complete with self-sealing rubber grommet. For installation into 12" or 16³/₁₆" diameter holes. Easy snap-in installation with grommet cord.



Size	Part No.
12"	1031143
16"	1013055

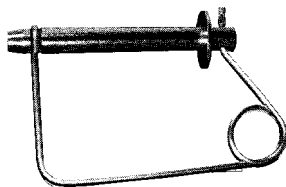

Tempered Spring Steel Snap-Lock Pins For Anti-Nose Dive Legs Other Miscellaneous Uses		
Part No.	Dia.	Usable Length
1012039-1/2	1/2"	3 ¹ / ₂ "
1012039-5/8	5/8"	4"
1012039-3/4	3/4"	4"



Stainless Steel Lock Pin		
Part No.	Dia.	Usable Length
1012040	5/16"	2 ¹ / ₂ "

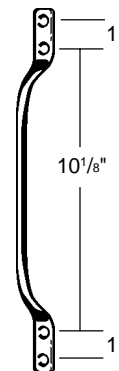

Chrome Grab Handle
1/2" diameter steel rod. 13" overall 2" high, with 7" grab. Drilled and countersunk for 1/4" screws. Commercial chrome finish.
Part No. 1014218

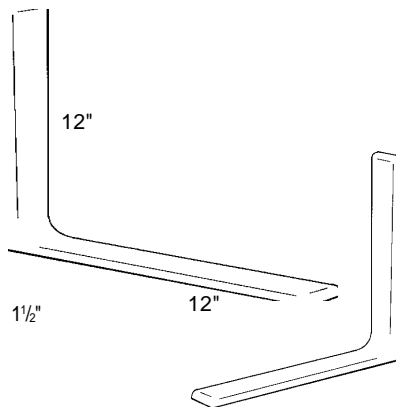

Corner Reinforcement	
Heavy duty drop forged corner iron.	
Part No.	Size
1010083	12" x 12" x 1 ¹ / ₂ "

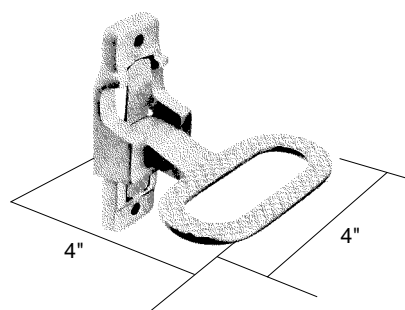

Folding Step
Investment cast, folding grab or step, zinc plated. Stainless spring holds step in open or closed position. Non-skid step surface. Four inches wide, extends 4 inches when unfolded. Part No. 1032157





TRAILER BODY PARTS ACCESSORIES

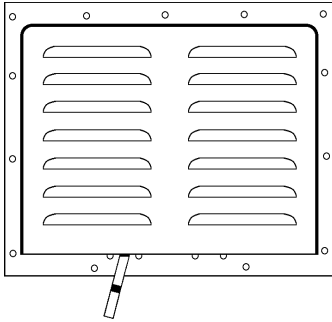

Adjustable Vent

Aluminum. Fits 11¹/₄" x 9¹/₂" opening. Lever allows adjustment of air flowing through four 2" diameter holes.

Part No.	Size
1024359	12 ¹ / ₄ " x 10 ¹ / ₂ "

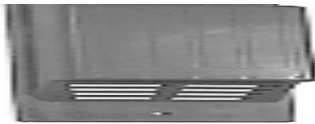

Container Vent

Plastic. Three hole mounting, vents angled on one side.

Part No.	Size
1310520	8 ¹ / ₈ " x 2 ¹¹ / ₁₆ "

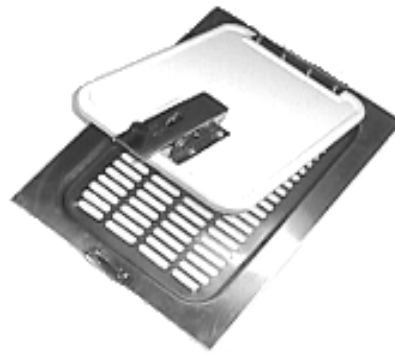

Vent Door Assembly

White double sealed foamed door with aluminum frame with screen.

Door Ass'y Part No.	1105449
Door Latch Only	1105450
Outside Frame Flange	20" x 15"
Panel Cutout	17 ¹ / ₂ " x 11 ⁵ / ₈ "
Door Opening	16 ⁷ / ₈ " x 11 ⁵ / ₁₆ "



Tire Carriers

Heavy duty 12 gauge formed steel. Black primer finish. Accomodates tires up to 11.00 x 22.00. Available assembled or unassembled. Chain and clip included.

Description	Part No.
Assembled	1010323
Unassembled	1011590
Chain & Clip Ass'y	C-2325

Nash Style Spare Tire Carrier Mounting Kit

- Black Primer finish
- Includes zinc plated hardware
- Enable installation to I-Beam crossmembers

Part No. 981-00055



Recessed Gladhand and Electrical Mounting Pans

Recessed pans for use on trailer front ends to recess and protect manifest boxes, gladhands and other front end fixtures. Manufactured from molded ABS material or formed aluminum.

PAN "A"
.063 aluminum
with back plate

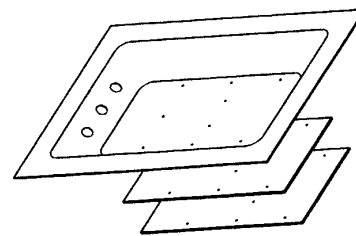

Pan "A"

Part No.	Thickness	Bottom of cavity	Cutout Size	Overall	Flange	Draft	Application/Replaces
1206116	2 ¹ / ₂ "	10" x 17"	13" x 20"	17" x 23"	2 ¹ / ₄ "	10°	Dorsey

PAN "B"
.063 Aluminum

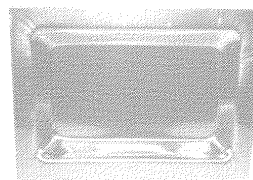

Pan "B"

Part No.	Thickness	Bottom of cavity	Cutout Size	Overall	Flange	Draft	Application/Replaces
1206117	2 ¹ / ₄ "	9 ³ / ₄ " x 16 ³ / ₄ "	12 ¹ / ₂ " x 19 ⁵ / ₈ "	18" x 25"	2 ¹ / ₄ "	10°	Dorsey



TRAILER ROOF COIL

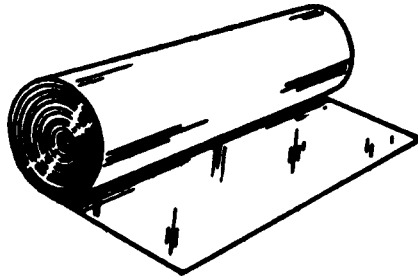

Approximate weight per running foot
103" Wide Coils: 4.90 lbs.

Master Coils	
.040 Thickness, 303H16	
Width	Part No.
103"	040X103

Master coils are aluminum trailer roof coil in bulk quantities and are sold by the pound. They vary in weight, with most coils weighing approximately 4000 pounds. This makes a 103" coil approximately 829 feet long.

Cut To Length Coils	
.040 Thick, 3003H16	
103" Wide	
29'	1164512
49'	1164514
54'	1164517

TRANSLUCENT GLASBORD ROOF PANELS

**Kemlite®
TRANSLUCENT
GLASBORD ROOF PANELS**

Fiberglass .060 & .075 thick roof material in precut coils. 102" wide.

Length	Part No.
28'	NL060X102X28
29'	NL075X102X29
50'	NL075X102X50
54'	NL075X102X54
29'	NL075X102.5X29
54'	NL075X102.5X54

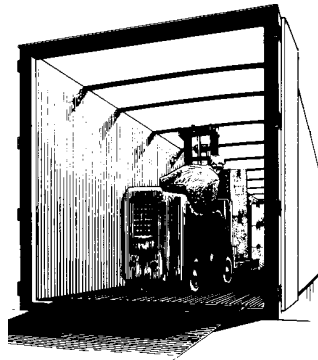

Master Coils	
.075 Thickness : 500 FT	
Width	Part No.
102"	NL075X102XMC

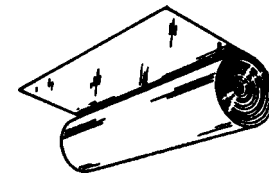

KEMLITE TRANSLUCENT ROOF REPAIR KITS

Kemlite®



Kemlite Roof repair Kit Part No. 1164524	
CONTENTS:	
1	Quart of T-Mix
1	Tube of catalyst (1/2 Oz.)
1	2' x 4' piece of chopped strand mat
1	3' x 4' piece of embossed film
1	3' x 4' piece of smooth film
2	Mixing cups (1 pint)
2	Squeegees
2	Mixing sticks
1	Pair of gloves

Kemlite SunPatch® Fiberglass Repair Kit



Repairs small tears and punctures (12X12)
Cures in 10 minutes after exposure to UV rays
Works in hot or cold climates (0 - 100 degrees F)
No mixing of resin required.

Kit contains 1 patch , 1 squeegee, 2 gloves,
application instructions, and one MSDS sheet.
Part No. 1164530



FIBERGLASS SCUFFPLATE

We are your SOURCE for the sizes you need in heavy duty

Kemlite®

Fiberglass Scuffplate

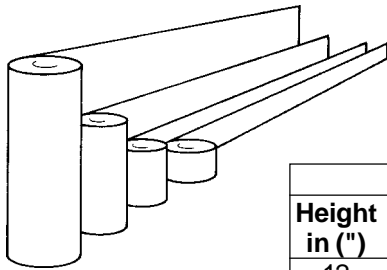

Plastic Divider
Stock Length 96"
Part No. X213X96

.090 (3/32") Thickness		
Height in (")	Length in Feet	Part Number
12	48	NL090X12X48
12	53	NL090X12X53
16	48	NL090X16X48
16	53	NL090X16X53
24	48	NL090X24X48
24	53	NL090X24X53
48	48	NL090X48X48
48	53	NL090X48X53
96	48	NL090X96X48
96	53	NL090X96X53
101	53	NL090X101X53
4' X 9' Sheet		NL090X4X9

.120 (1/8") Thickness		
Height in (")	Length in Feet	Part Number
12	48	NL120X12X48
12	53	NL120X12X53
16	48	NL120X16X48
16	53	NL120X16X53
24	48	NL120X24X48
24	53	NL120X24X53
48	48	NL120X48X48
96	48	NL120X96X48
4' X 8' Sheet		NL120X4X8

HARDWOOD WEARBAND

ALUMINUM WEARBAND

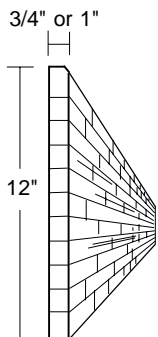

LAMINATED OAK

Part No.	Description
3/4X568	568" Long (47 Feet, 3+ Inches)
3/4X624	624" Long (52 Feet)
1X624	624" Long (52 Feet)

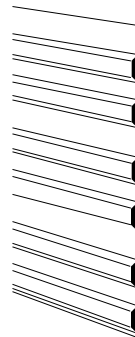

Aluminum for weight savings.
1.5 lbs. per foot.

Part No.	Description
X511X564	Extruded aluminum, 12" high, (47 feet)
X511X624	Extruded aluminum, 12" high, (52 feet)

STEEL WEARBAND

TUF-SKUF®

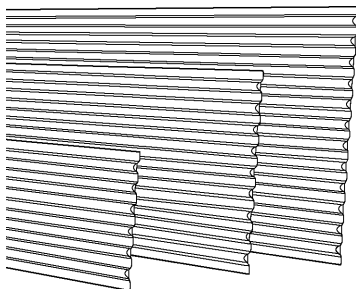

Hot dip galvanized steel wearband

Corrugated with closed end corrugations for no-sag loading and unloading. Valley mounted fasteners are scuff proof.

12" High WEARBAND	
Part No.	Description
1014343-47	12" high corrugated steel, 47 feet long.
1014343-52	12" high corrugated steel, 52 feet long.
18" High WEARBAND	
1014344-47	18" high corrugated steel, 47 feet long.
1014344-52	18" high corrugated steel, 52 feet long.



PLASTIC SCUFFPLATE

Plastic Scuffplate

Plastic scuffplate is made from high density polyethylene (HDPE), prime pigment, UV-inhibitors, and selected process additives. The HDPE raw material comes from post-consumer waste such as milk bottles as well as manufacturing seconds such as aspirin and soap bottles. This material is cleaned to a purity level of 99% or above HDPE. It resists moisture, corrosion, insect infestation and other elements. It will not absorb moisture, therefore it cannot warp, splinter, crack or rot. Cyclewood plastic scuffplate can be drilled, cut, or routed.

Current forms of adhesives are not recommended.

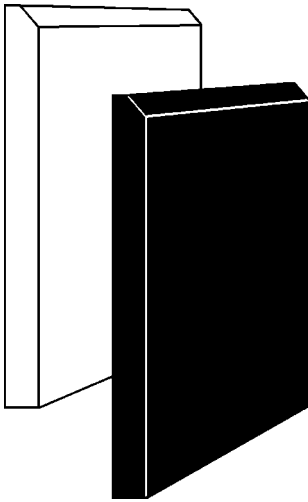

27 Foot Length		
Color	Description	Part No.
Black	5/8" x 12" x 27'	1014345
47 Foot Length		
Color	Description	Part No.
Black	5/8" x 12" x 47'	1014346
White	5/8" x 12" x 47'	1014347
52 Foot Length		
Color	Description	Part No.
Black	5/8" x 12" x 52'	1014348
White	5/8" x 12" x 52'	1014349

TRAILER FLOORING

LAMINATED HARDWOOD FLOORING SHIPLAP, 12 INCH FACE WIDTH

1 1/8" ("A") THICK BOARDS	
Length	Part No.
26'	11/8X312
47' 3"	11/8X568
1 1/4 ("A") THICK BOARDS	
Length	Part No.
26'	11/4x312
47' 3"	11/4x568
1 3/8 ("A") THICK BOARDS	
Length	Part No.
26'	13/8X312
47' 3"	13/8X568

Restore your Trailer Flooring with Key Polymer Floor Restore Kits! See them in our chemical section!

KEY POLYMER CORP.

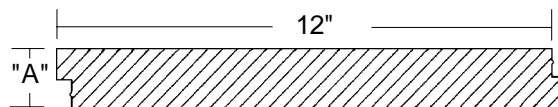
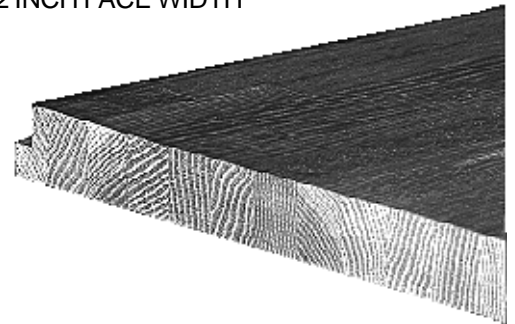

APITONG FLOORING

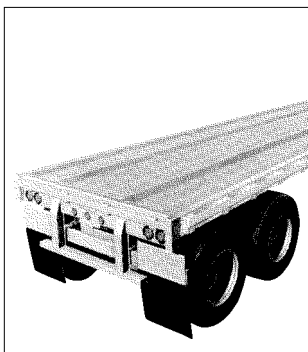

Shiplap
5 and 7 Inch Widths
8' to 20' Random Lengths

Board Width	Part No.
7"	1-1/8X7AP
5"	1-3/8X5AP
7"	1-3/8X7AP

Note: Sold by the running foot.

CONTAINER FLOORING PANELS

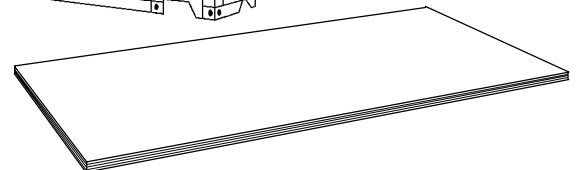
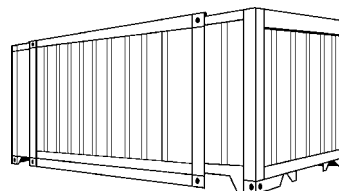

19 Ply, 1 1/8" Thick, 4' x 8', Australian Treated
Part No. 1310119



STEEL PARTS FOR WOOD FLOORS & BOLT KITS

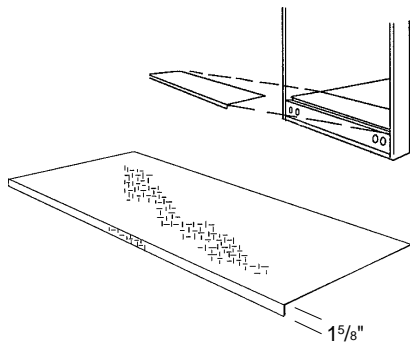

Trailer Threshold Plate

Tough 1/8" steel diamond plate. Protects expensive wood flooring from fork lift wear and tear. 1 3/8" lip.

Part No.	Size
1063098	22 5/8" x 96"

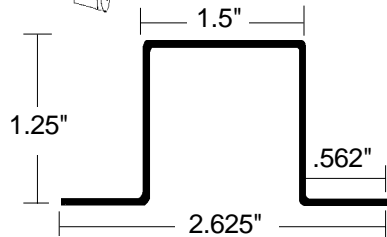
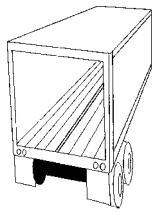

Floor Center Board Channel

Galvanized steel, 14 gauge. 48' long.

Part No.	Size
1063099	See Above



Bolt Kit For Bottom Side Rail

Contains (8) 3/8"-24 x 11/4" TORX® Drive Button Head Grade 8 Screws with Nylon Insert Lock Nuts

(Enough bolts and nuts for one crossmember installation)

Part No. 1157013

TRAILER CROSSMEMBERS

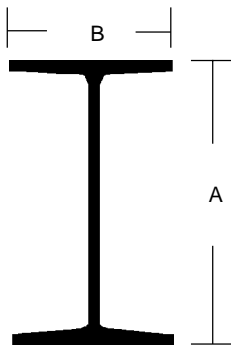

Steel Crossmember

80,000# PSI

Part No.	"A"	"B"	Length	Lb/Ft
1157033	3"	2.25"	102"	2.9
1157022	4"	2.25"	96"	3.2
1157031	4"	2.25"	102"	3.2
1157039	6"	2.00"	102"	3.7

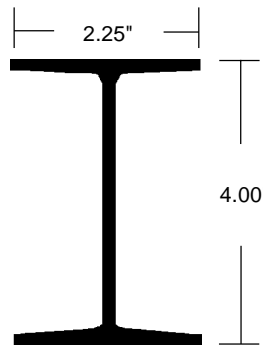

Heavy Duty

4" Steel Crossmember

Intermodal Specifications
80,000# PSI

Part No.	Length	Lb/Ft
1157034	102"	3.45

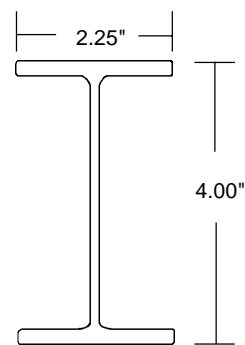

4" Aluminum Crossmember

6061T6 Aluminum Alloy

Part No.	Length
1157030	102"

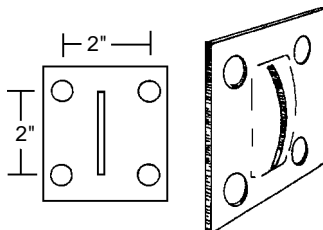

Crossmember Clip

3 1/8" High, 3 1/2" Wide

Part No.	Replaces
1157016	--

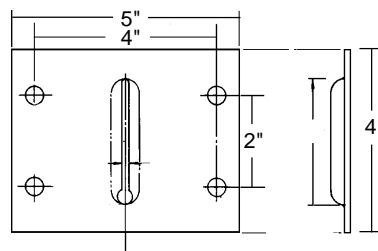

Sill Clip

Part No.	Replaces
1157023	4x5, No holes, w/slot
1157024	4-Hole, 4x5, 2x4 Centers, w/slot

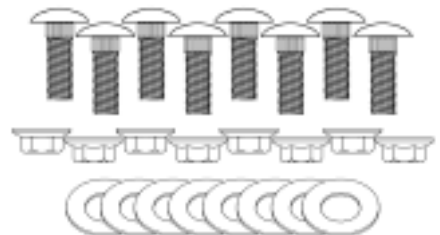

Crossmember Bolt Kit

Contains fasteners for one trailer crossmember installation; 8 heat treated splined step bolts, 8 nylon washers, and 8 flanged lock nuts. (shown)

Part No. 1157015
Part No. 1157012 (torx head-no washers)

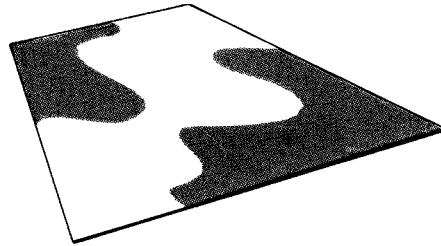
**TRAILER SIDE PANELS**

**FLAT
AND
CORRUGATED**

FLAT PANELS

PART NUMBER	DESCRIPTION	COMMENTS
STEEL		
0262X49X110WH	49" X 110" STEEL GALAVAN PPW*, .026" Thick	
.050" ALUMINUM, MILL FINISH		
1206134	49" X 120" MILL FINISH ALUMINUM	
.050" ALUMINUM, PREPAINTED		
050X49X110WH	49" X 110" PPW* ONE SIDE, MILL FINISH OPPOSITE	PVC PROTECTIVE COATING
050X49X110WHLP	49" X 110" PPW* ONE SIDE, MILL FINISH OPPOSITE	LESS PROTECTIVE COATING
050X49X120WH	49" X 120" PPW* OPPOSITE, MILL FINISH OPPOSITE	PVC PROTECTIVE COATING

CORRUGATED PANELS

1190166WH	FRUEHAUF PANEL, 66 CORRUGATIONS, PPW*	
1190224	DORSEY PANEL, 24 CORRUGATIONS, PPW*	
1190215	GREAT DANE, 15 CORRUGATIONS, PPW*	
1190216	GREAT DANE, 16 CORRUGATIONS, PPW*	
1190316	TRAILMOBILE, 16 CORRUGATIONS, PPW*	4" & 8" CORR. CENTERS
1190315	UTILITY, 15 CORRUGATIONS, PPW*	

ABBREVIATIONS: PPW: Prepainted White

VANFASTIC**Aluminum Repair Kit Self Adhesive Aluminum & Translucent Patches For Panel Repairs**

Can be impressed over rivets. Vanfastic will not add structural integrity; the repair is for cosmetic purposes only.

Kit No. V1212W

contains ten 12" x 12" self adhesive white aluminum sheets.

Kit No. V1224W

contains five 12" x 24" self adhesive white aluminum sheets.

Kit No. V1224T

contains five 12" x 24" self adhesive translucent sheets.

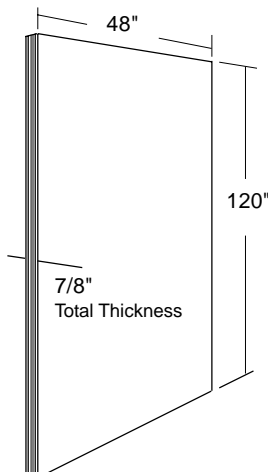

FRP Panels
3/4" Wood Core
7/8" Total Thickness
48" Wide, 120" Long
Part No. 7/8X48X120

FRP Nut & Bolt

Part No. 1010360
Camtainer Nut
Part No. 1010361
Camtainer Bolt

200 pcs/bag

**Just peel
and apply
over
damaged
area**





TRAILER BODY PARTS NOMENCLATURE

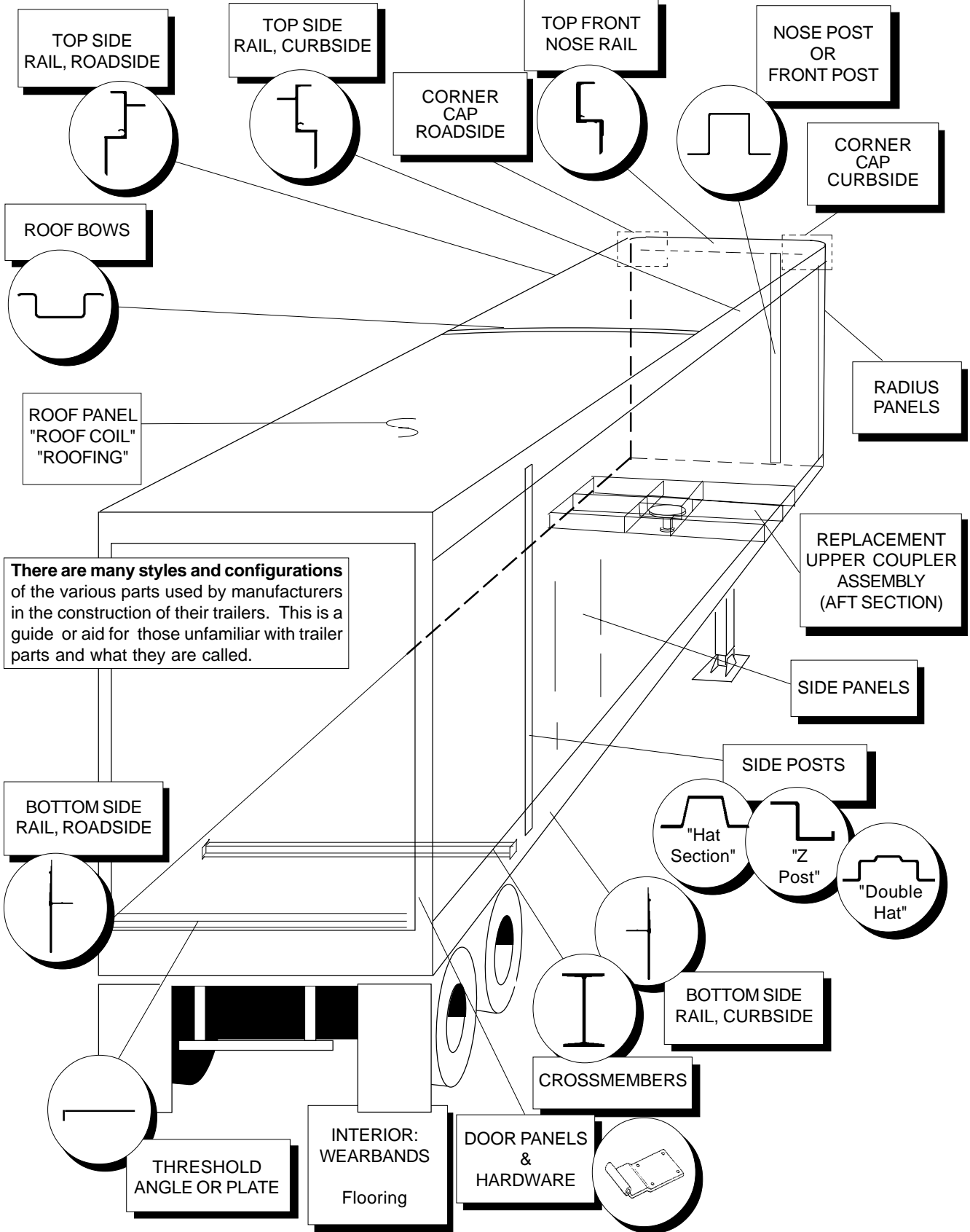

TOP SIDE RAIL, ROADSIDE

TOP SIDE RAIL, CURBSIDE

TOP FRONT NOSE RAIL

NOSE POST OR FRONT POST

CORNER CAP ROADSIDE

CORNER CAP CURBSIDE

ROOF BOWS

ROOF PANEL "ROOF COIL" "ROOFING"

RADIUS PANELS

REPLACEMENT UPPER COUPLER ASSEMBLY (AFT SECTION)

SIDE PANELS

SIDE POSTS

"Hat Section"

"Z Post"

"Double Hat"

BOTTOM SIDE RAIL, ROADSIDE

BOTTOM SIDE RAIL, CURBSIDE

CROSSMEMBERS

DOOR PANELS & HARDWARE

INTERIOR: WEARBANDS
Flooring

THRESHOLD ANGLE OR PLATE



STRICK BODY PARTS



PARTNERSHIP IN PARTS

OUTER RADIUS

Part No. SK47158

7" white aluminum radius
A: 105¹/₂" B: 13¹/₂" C: 10³¹/₃₂"

Part No. SK16313

white aluminum
A: 105¹/₂" B: 10¹/₄" C: 8³/₁₆"

Part No. SK14408

white aluminum
A: 104¹/₂" B: 13⁵/₁₆" C: 8³/₁₆"

Part No. SK45305

7" blue aluminum radius
A: 107¹/₂" B: 13¹/₂" C: 10³¹/₃₂"

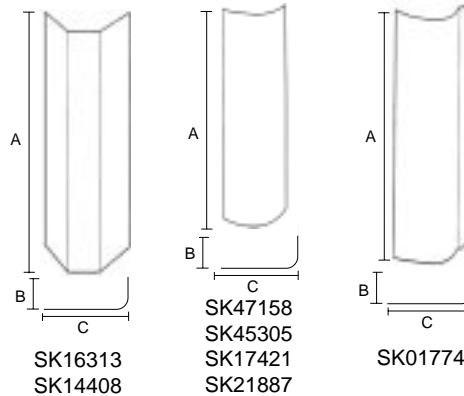

Part No. SK01774

5" .090" white aluminum
A: 110¹/₂" B: 8¹/₂" C: 13⁵/₁₆"

Part No. SK17421

7" bare aluminum radius
A: 105¹/₂" B: 13³/₁₆" C: 8¹/₈"

Part No. SK21887

7" white aluminum radius
A: 101¹/₂" B: 13⁵/₁₆" C: 15"

Part No. SK52535 (not shown)

7" aluminum radius
A: 114¹/₂" B: 13⁹/₁₆" C: 8¹/₈"

TOP SIDE RAIL

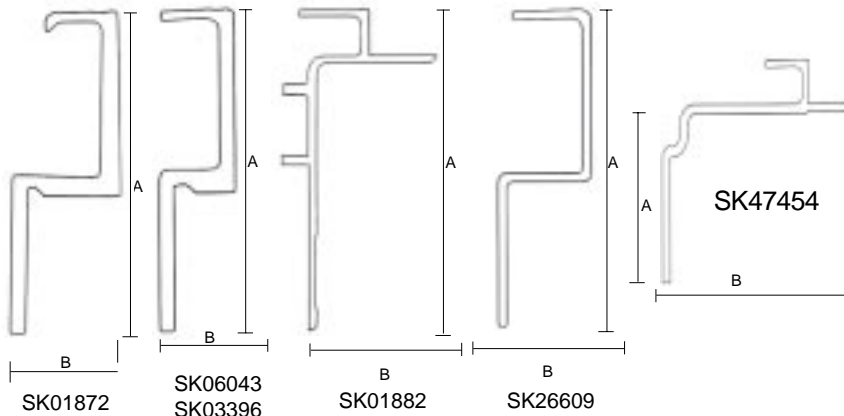

Part No. SK01872

A: 5⁹/₁₆" B: 1⁹/₃₂" 51⁹/₄"

Part No. SK06043

A: 5⁹/₁₆" B: 1²¹/₃₂" 51⁹/₈"

Part No. SK03396

A: 5⁹/₁₆" B: 1¹³/₁₆" 51⁹/₄"

Part No. SK01882

A: 6¹³/₁₆" B: 3¹/₈" 51⁷/₄"

Part No. SK26609

A: 5⁹/₁₆" B: 1¹¹/₁₆" 27³/₄"

Part No. SK47454

A: 5" B: 6" 51⁹/₄"

NOSE RAILS

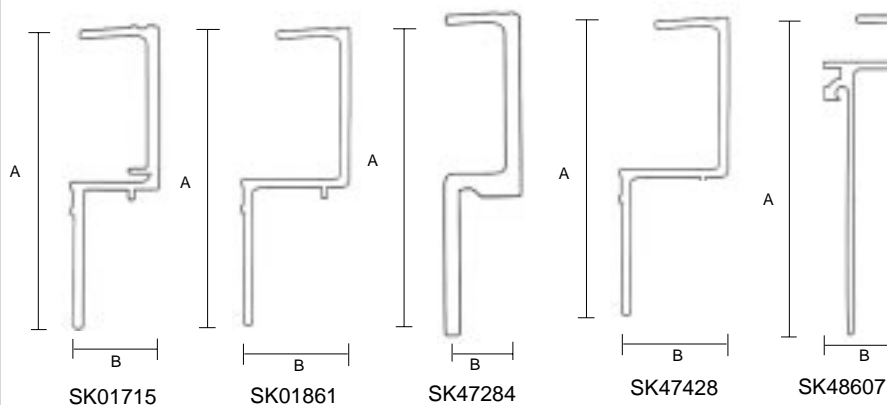

Part No. SK01715

one pc. wrap around style, 98¹/₂", 7" radius
A: 5⁹/₁₆" B: 1⁹/₃₂"

Part No. SK52017

straight section for 3 pc. style, 91⁷/₈"
A: 5⁹/₁₆" B: 1²¹/₃₂"

Part No. SK47284

straight section for 3 pc. style
A: 5.5625" B: 1.057"

Part No. SK47428

straight section for 3 pc. style, 85¹¹/₁₆"
A: 5" B: 6"

Part No. SK48607

1 pc. wrap around style, 102⁵/₈" 5" radius



STRICK BODY PARTS

ROOF BOWS

a

b

c

d

aluminum

Part No. SK27820	98 ^{7/8} " standard arch-a
SK01510	98 ^{7/8} " high arch-a
SK01511	92 ^{15/16} " high arch-a
SK48533	98 ^{1/8} " high arch-a
SK01512	100 ^{3/8} " high arch-a
SK01513	99 ^{7/16} " high arch-a
SK05250	98 ^{7/8} ", 3 piece-b
SK16012	98 ^{1/2} ", hat style arch-c
SK06686	93", anti-snag-d(galv)
SK45324	93", anti-snag-d(alum)

CORNER CAPS

	Part No. SK14394	right/curb side
	SK14393	left/road side
	SK01792	universal, left side & right side
	SK03500	universal, left side & right side
	SK45290	universal, left side & right side
	SK01792	7" radius
	SK45290	7" radius
	SK03500	7" radius

BOTTOM RAIL SPLICE

<p>Part No. SK17344 Bottom Rail Splice Plate 18 5/8" Long-Steel-Punched for Bottom Rail #'s SK01854, SK01857</p>	<p>Part No. SK51322 Bottom Rail Splice Angle 8 1/2" Long-Steel-Punched for Bottom Rail #'s SK01854, SK01857</p>
---	--

TOP RAIL SPLICE

<p>Part No. SK27572 Outer Top Rail Splice 20' Long-Aluminum For Top Rail #'s SK01872, SK06043</p>	<p>Part No. SK47598 Inner Top Rail Splice 18 1/2" Long-Steel-Punched For Top Rail #'s SK01872, SK06043</p>
--	---

L/G GUSSET

Part No. SK03690	roadside L/G gusset
Part No. SK03691	curbside L/G gusset
Part No. SK01112	roadside L/G gusset
Part No. SK04101	curbside L/G gusset

REAR FRAME HEADER

Part No. SK05228	rear header assembly
Part No. SK01436	rear header assembly

ICC ASSEMBLY

Part No. SK01185	steppuardassembly
Part No. SK27856	steppuardassembly
Part No. SK47336	steppuardassembly
Part No. SK27687	ICC bolt on tubeassy
Part No. SK26883	ICCassembly
Part No. SK26950	ICCassembly

FRP BACKUP STRIP

Part No. SK18165	Length: 26', 6 ^{7/8} " A: 1 ^{5/8} " B: 1 ^{1/4} " backup strip for top rail installation on FRP trailers
Part No. SK17718	Length: 26', 6 ^{3/4} " x 3.625" A: 3.625" B: 1/4" backup strip for bottom rail installation on FRP trailers

SK17718



STRICK BODY PARTS

SIDE POSTS
INNER RADIUS
BOTTOM SIDE RAILS
CROSS-MEMBER ASSEMBLY

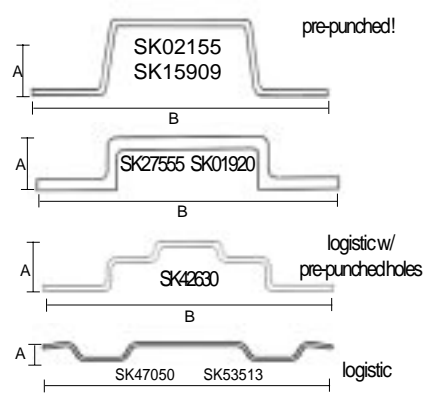

Part No. SK02155 (steel)
A: 1⁵/₁₆" B: 5¹/₄" 107¹/₂

Part No. SK15909 (alum.)
A: 1¹/₄" B: 5¹/₄" 111¹/₂

Part No. SK27555 (alum.)
A: 29³/₃₂" B: 5¹/₄" 116³/₁₆

Part No. SK01920 (steel)
A: 11¹/₁₆" B: 5⁻¹/₂"

Part No. SK42630 (steel)
A: 3⁴/_" B: 5" 107³/₈"

Part No. SK53513 (alum.)
A: 15¹/₁₆" B: 6⁷/₈" 104¹/₄"

Part No. SK47050 (steel)
A: .45" B: 6³/₄" 109³/₄"

NOSE POSTS
REAR FRAME POST

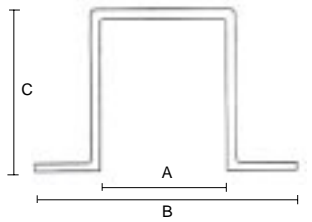

Part No. SK01738 (STEEL)
LENGTH: 122¹/₄" DEPTH: 3¹/₄"
A: 2¹/₁₆" B: 5¹/₄" C: 3¹/₄"

Part No. SK06625
LENGTH: 109" DEPTH: 1⁻⁵/₁₆"
A: 2³/₄" B: 5¹/₄" C: 1⁵/₁₆"

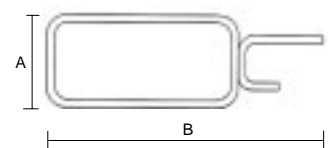

Part No. SK01418
A= 2" B=6"
rear corner post assembly
120" left hand-roadside

Part No. SK01420
A= 2" B=6"
rear corner post assembly
120" right hand-curb side

Part No. SK03903
universal galvanized steel
A: 101" B: 5¹/₂" C: 5¹/₂"

Part No. SK44094
universal galvanized steel
A: 105" B: 11⁹/₃₂" C: 14³/₄"

Part No. SK45309
universal galvanized steel
A: 103" B: 7¹¹/₁₆" C: 15³/₄"

Part No. SK06782
universal galvanized steel
A: 105" B: 9⁶³/₆₄" C: 16³/₁₆"

Part No. SK27541
universal galvanized steel
A: 107¹/₂" B: 4" C: 4¹¹/₁₆"

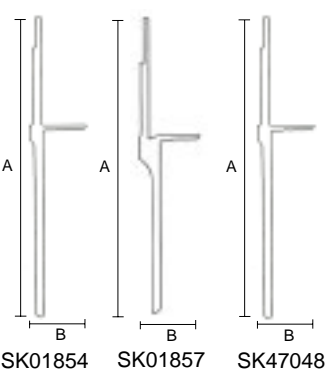
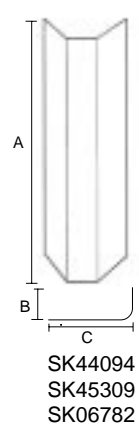
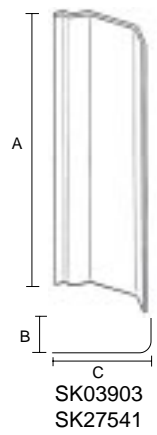

Part No. SK01854
51' length, 10⁵/₈"
A: 8³/₄" B: 1¹/₂"

Part No. SK01857
51' length, 10¹³/₁₆"
A: 8³/₄" B: 1³/₁₆"

Part No. SK47048
27' length, 4⁵/₈"
A: 8³/₄" B: 1³/₁₆"

J-MOULDING

Part No. SK01803
"J" moulding, 1.50" X 12"
Strick style.
Inner Dimension: .377
Outer Dimension: .281



REAR SILL ASSEMBLY

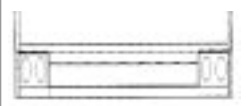

Part No. SK48714
rear sill (assembled)



Part No. SK01695
steel assembly,
4" x 101³/₈" primed black with
welded clips; 3.2# per foot,
80,000 lb. square inch
minimum yield.

FLOOR CHANNEL

Part No. SK52402
A=1¹⁹/₆₄ B=2¹/₂
aluminum has section
air electric conduit
44' 4³/₈"

HINGE STRAPS

Part No. SK01361
hinge strap

Part No. 1010170
hinge strap

Part No. 1010171
hinge strap

Part No. SK01330
hinge butt